

JUMO GmbH & Co. KG
 Delivery address: Mackenrodtstraße 14,
 36039 Fulda, Germany
 Postal address: 36035 Fulda, Germany
 Phone: +49 661 6003-0
 Fax: +49 661 6003-607
 E-mail: mail@jumo.net
 Internet: www.jumo.net

JUMO Instrument Co. Ltd.
 JUMO House
 Temple Bank, Riverway
 Harlow, Essex CM20 2DY, UK
 Phone: +44 1279 635533
 Fax: +44 1279 635262
 E-mail: sales@jumo.co.uk
 Internet: www.jumo.co.uk

JUMO Process Control, Inc.
 8 Technology Boulevard
 Canastota, NY 13032, USA
 Phone: 315-697-JUMO
 1-800-554-JUMO
 Fax: 315-697-5867
 E-mail: info@jumo.us
 Internet: www.jumo.us



JUMO DICON 400/500

Universal process controllers

Brief description

This series of universal, freely configurable process controllers is available in the formats 96mm x 96mm and 96mm x 48mm (portrait and landscape format).

The instruments feature two 4-digit 7-segment displays, five or eight LEDs for indication of the switching status and operating modes, an 8-digit matrix display, as well as six keys for operation and configuration.

The user has flexibility in assigning the slots of the controller according to the block structure. Additional functions include self-optimisation, parameter set switching, and up to eight limit comparators.

Linearisations for conventional transducers are held in the memory; a customized linearisation table can be programmed.

The process controller can be adapted to a variety of tasks with the aid of a maths module.

The instruments can be integrated into a data network via a serial interface, or can be expanded through an external relay module.

A setup program is available for easy configuration from a PC.

The electrical connection is at the rear by screw terminals.



JUMO DICON 500
 Type 703570/0...



JUMO DICON 400
 Type 703575/1...



JUMO DICON 400
 Type 703575/2...

Block structure

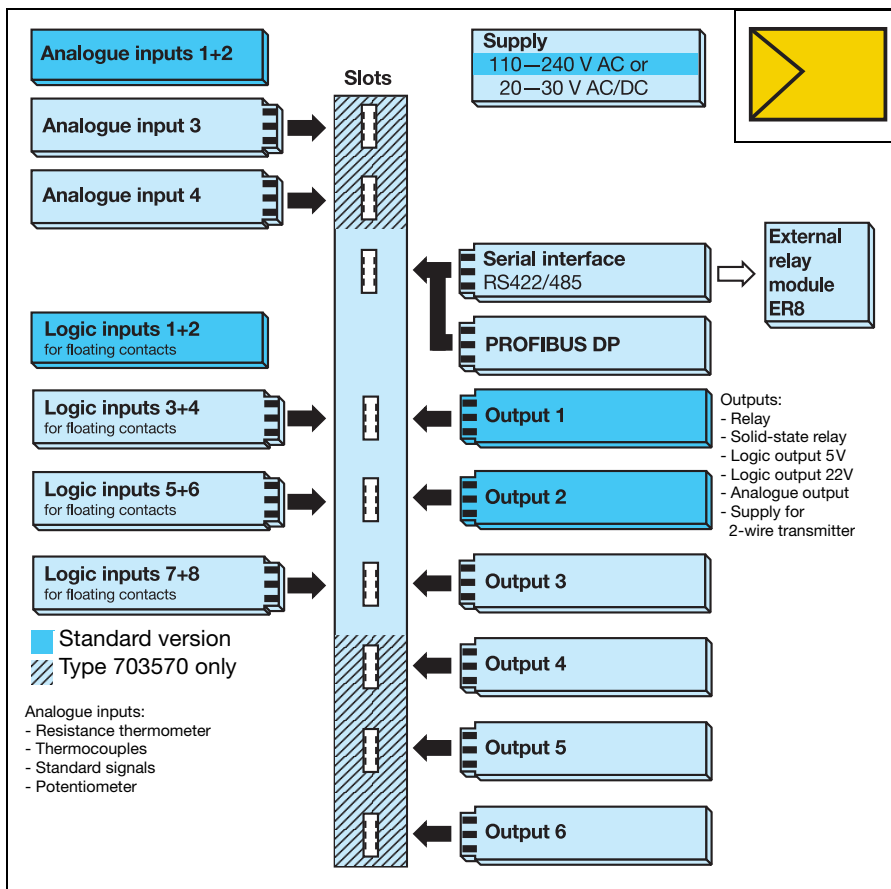

Features

- Switchable displays
- Text or bar graph display
- 8 limit comparators
- 4 setpoints
- 2 parameter sets
- Maths and logic module
- Ramp and profile program function
- Setup program with JUMO start-up software for Windows® 95/98/NT4.0/2000/XP/Vista

Approvals/approval marks (see Technical data)



Self-optimisation

The standard specification includes an auto-tuning facility which permits the user to adjust the controller to the process without any control engineering know-how. Auto-tuning evaluates the reaction of the process to certain changes of the output variables. The controller parameters X_p , T_n , T_v and C_y are calculated.

Ramp function

This function enables a defined approach of the process value from t_0 to the current setpoint.

The slope is adjusted via a gradient ($^{\circ}\text{C}/\text{min}$, $^{\circ}\text{C}/\text{h}$ or $^{\circ}\text{C}/\text{day}$) at configuration level 1. On a setpoint change, it is active either as a rising or a falling ramp.

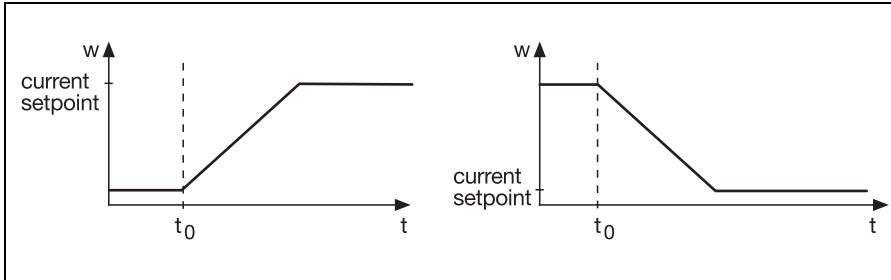

Profile program function

It is possible to produce a profile program with up to eight segments. The segment setpoints ($W_SEG01 - W_SEG08$) and segment times ($T_SEG01 - T_SEG08$) are defined at an additional level. The segment times can be programmed from 00:00:00 to 99:59:59 (format: hh:mm:ss).

The program starts at the program start or the process value. When starting at the process value, the profile is searched to find a setpoint which corresponds to the process value at the instant of the start. The profile then continues from this point. If the process value is outside the profile, a start is made at the first program segment. The program can either be run through once, or it can be repeated cyclically. Furthermore, it is possible to hold the program.

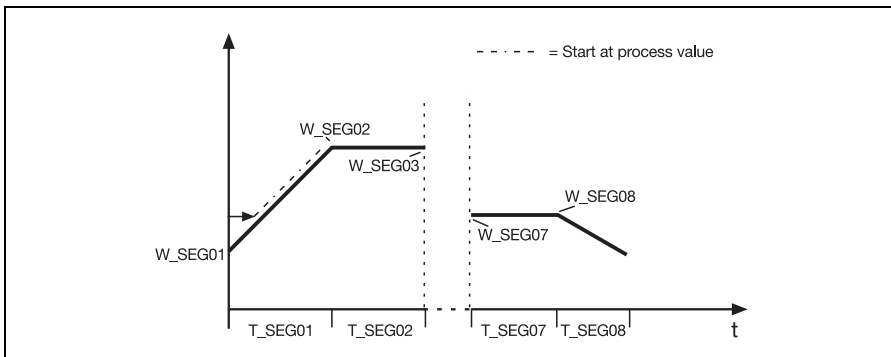

Fuzzy logic

In addition to the standard parameters, the controller software also contains a fuzzy logic software module. This can be used to improve both the control and the disturbance action via two parameters.

Customized linearisation

As well as the linearisations for conventional transducers, a customer-specific linearisation can be created.

Programming is performed via the setup program, in the form of a table of values.

Maths and logic module (option)

The maths module can be used to integrate, for instance, setpoints, outputs and the measured values of the analogue inputs into a mathematical formula.

Through the logic module it is possible to logically link logic inputs and limit comparators, for example.

Two formulae can be entered via the setup program for each of the two modules. The results of the calculations can then be produced via the outputs or can be used for internal purposes.

There is the additional possibility of implementing controls for difference, ratio and humidify through standard formulae.

Configurable displays

Any process variable can be visualised on the 7-segment displays and the dot-matrix display.

It is possible to switch between two displays either from the keys, or automatically after an adjustable interval.

Text display

The functions of the logic inputs, the limit comparators and the logic outputs of the logic module can have customer texts assigned to them.

Depending on the status of the function or the configuration of the displays, a programmed text (8 characters max.) is shown on the matrix display.

The customer texts can only be created using the setup program.

Setup program (accessory)

The setup program for configuration is available in English, German and French. A PC can be used to create and edit data sets, transfer them to the controller or read them out of the instrument. The data sets are stored and managed.

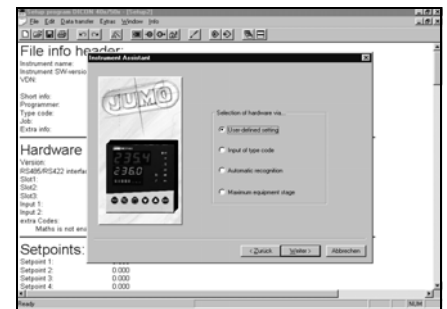

JUMO Start-up software

The JUMO start-up software is an integral part of the setup program and is available for conveniently adapting the controller to the process.

Different process variables (e. g. setpoint, process value, control deviation, signals from the controller outputs) can be displayed graphically. The controller parameters can be altered and transferred to the controller via the setup or RS422/485 interfaces.

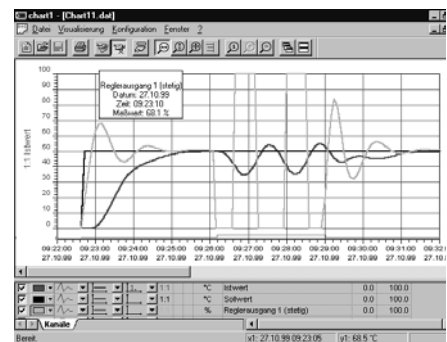

RS422/RS485 interface (option)

The serial interface is available for communication with higher-level systems. MODbus/Jbus are used as transmission protocols.

PROFIBUS-DP (option)

The controller can be integrated into a fieldbus system to the PROFIBUS-DP standard, via the PROFIBUS-DP interface. This PROFIBUS variant has been designed specifically for the communication between automation systems and decentralised peripheral instruments at the field level, and is speed-optimised. The data are transmitted serially in accordance with the RS485 standard. Using the project design tool included in the delivery (GSD-generator; GSD = instrument master data), a standardised GSD file is created that serves to integrate the controller into the fieldbus system, through selection of characteristic controller data.

External relay module ER8 (accessory)

The controller can be expanded by eight relay outputs through the external relay module ER8. Operation is by the RS422/RS485 interface. The setup program is necessary for configuring the ER8, which can be mounted on a standard DIN rail.

Functions of the logic inputs

- Start/cancel self-optimisation
- Changeover to manual mode
- Manual mode inhibit
- Ramp stop
- Ramp off
- Setpoint switching
- Process value switching
- Parameter set switching
- Key/level inhibit
- Text display
- All displays off
- Profile program start/stop

Functions of the outputs

- Analogue input variables
- Mathematics
- Process value
- Setpoint
- Control deviation
- Output
- Controller outputs
- Limit comparators
- Logic inputs
- Logic
- Manual mode signal

Operation, parameterization, configuration

Operation, setting of the controller parameters and configuration are arranged at different levels.

Operating level

Setpoints, measurements of the analogue inputs, maths as well as the controller output can be indicated here.

Profile program function

The eight segments of the profile program function are programmed here. This level only appears when the profile program function has been activated.

Parameter level

The controller parameters are set here.

Configuration level 1

Here the basic functions of the instrument, such as controller function and setpoint switching, are set.

Configuration level 2

The hardware and software codes that correspond to the controller version, are shown here.

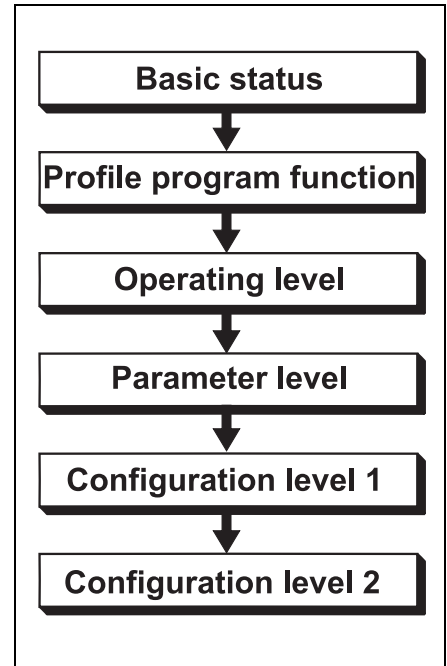

Displays and controls

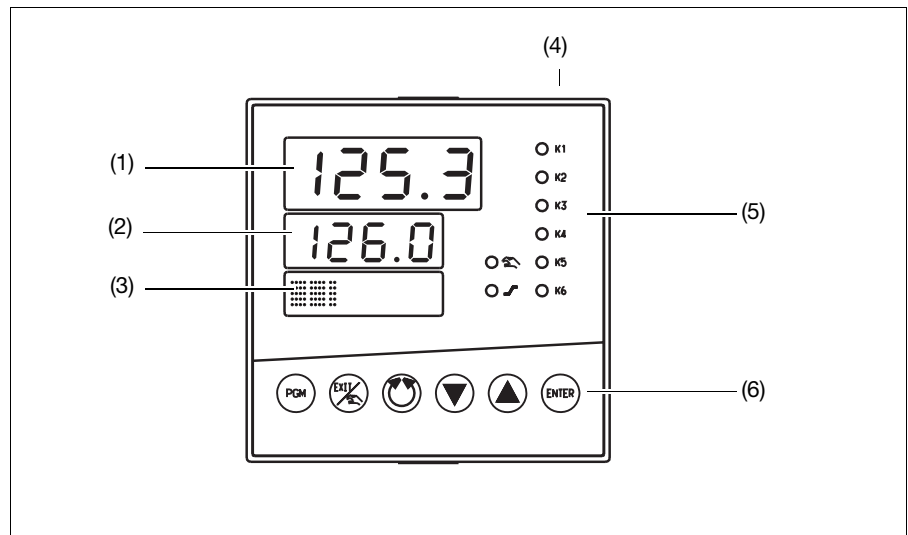

<p>(1) configurable 7-segment display 4 digits, red</p> <table border="1"> <thead> <tr> <th>Type</th> <th>Height</th> </tr> </thead> <tbody> <tr> <td>703570</td> <td>13mm</td> </tr> <tr> <td>703575</td> <td>10mm</td> </tr> </tbody> </table> <p>factory-set: process value</p>	Type	Height	703570	13mm	703575	10mm	<p>(4) Setup interface (for position, see dimensional drawings)</p>
Type	Height						
703570	13mm						
703575	10mm						
<p>(2) configurable 7-segment display 4 digits, green</p> <table border="1"> <thead> <tr> <th>Type</th> <th>Height</th> </tr> </thead> <tbody> <tr> <td>703570</td> <td>10mm</td> </tr> <tr> <td>703575</td> <td>7mm</td> </tr> </tbody> </table> <p>factory-set: setpoint</p>	Type	Height	703570	10mm	703575	7mm	<p>(5) Status indication 6 (3) yellow LEDs for status indication of the outputs 2 green LEDs to display manual mode and the ramp/profile program function</p>
Type	Height						
703570	10mm						
703575	7mm						
<p>(3) configurable dot-matrix display 8 digits, green factory-set: output (bar graph)</p>	<p>(6) Keys</p>						

Parameter level

The table below lists all the parameters, as well as their meaning. Depending on the controller type, certain parameters are irrelevant or not applicable. Two parameter sets can be stored for specific applications.

Parameters	Display	Value range	factory-set	Meaning
Controller structure	Structure 1	P, I, PD, PI, PID	PID	Structure 2 refers to the second output in the case of a double-setpoint controller
	Structure 2	P, I, PD, PI, PID	PID	
Proportional band	Xp1	0—9999 digit	0 digit	Size of the proportional band At Xp =0 the controller structure is not effective!
	Xp2	0 — 9999 digit	0 digit	
Derivative time	Tv1	0—9999 sec	80 sec	Influences the differential component of the controller output signal
	Tv2	0—9999 sec	80 sec	
Reset time	Tn1	0—9999 sec	350 sec	Influences the integral component of the controller output signal
	Tn2	0—9999 sec	350 sec	
Switching cycle time	Cy1	0—9999 sec	20 sec	For a switching output, the cycle time should be selected so that the energy supply to the process is virtually continuous while the switching devices are not overloaded.
	Cy2	0—9999 sec	20 sec	
Contact spacing	Xsh	0—9999 sec	0 digit	Spacing between the two control contacts for double-setpoint controllers, modulating controllers and proportional controllers with integral actuator driver.
Switching differential	Xd1	0—999 digit	1 digit	Differential of switching controllers for Xp = 0.
	Xd2	0—999 digit	1 digit	
Stroke time	TT	5—3000 sec	60 sec	Utilised stroke time of the control valve on modulating controllers and proportional controllers with integral actuator driver.
Working point	Y0	-100 to +100%	0%	Output on P and PD controllers (y = Y0 at x = w).
Output limiting	Y1	0—100%	100%	Maximum output limit
	Y2	-100 to +100 %	-100%	Minimum output limit
Minimum relay ON time	Tk1	0—60 sec	0 sec	Limitation of the switching rate on switching outputs
	Tk2	0—60 sec	0 sec	

Isolation

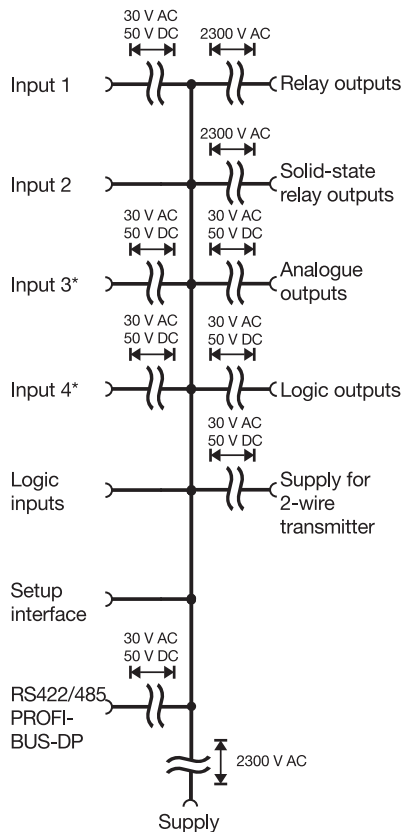

*Type 703570 only

Technical data

Thermocouple input

Designation	Range ¹	Meas. accuracy	Ambient temperature error
Fe-Con L	-200 +900°C	≤0.25%	100 ppm per °C
Fe-Con J EN 60 584	-200 +1200°C	≤0.25%	100 ppm per °C
Cu-Con U	-200 +600°C	≤0.25%	100 ppm per °C
Cu-Con T EN 60 584	-200 +400°C	≤0.25%	100 ppm per °C
NiCr-Ni K EN 60 584	-200 +1372°C	≤0.25%	100 ppm per °C
NiCr-Con E EN 60 584	-200 +1000°C	≤0.25%	100 ppm per °C
NiCrSi-NiSi N EN 60 584	-200 +1300°C	≤0.25%	100 ppm per °C
Pt10Rh-Pt S EN 60 584	0 – 1768°C	≤0.25%	100 ppm per °C
Pt13Rh-Pt R EN 60 584	0 – 1768°C	≤0.25%	100 ppm per °C
Pt30Rh-Pt6Rh B EN 60 584	0 – 1820°C	≤0.25% ²	100 ppm per °C
W5Re-W26Re	0 – 2320°C	≤0.25%	100 ppm per °C
W3Re-W25Re	0 – 2400°C	≤0.25%	100 ppm per °C
Cold junction	Pt100 internal, external or constant		

1. The specifications refer to an ambient temperature of 20 °C.

2. within range 300 – 1820 °C

Resistance thermometer input

Designation	Type of connection	Range	Meas. accuracy	Ambient temperature error
Pt100 EN 60 751	2-wire/3-wire	-200 +850°C	≤0.05%	50 ppm per °C
Pt 50, 500, 1000 EN 60 751	2-wire/3-wire	-200 +850°C	≤0.1%	50 ppm per °C
Cu50	2-wire/3-wire	-50 +200°C	≤0.1%	50 ppm per °C
Ni100 DIN 43 760	2-wire/3-wire	-60 +250°C	≤0.05%	50 ppm per °C
KTY21-6	2-wire	-50 +150°C	≤1.0%	50 ppm per °C
PTK9	2-wire	Lithium-chloride sensor		
Sensor lead resistance	max. 30Ω per conductor in 2-/3-wire circuit			
Measuring current	250µA			
Lead compensation	not required for 3-wire circuit. For 2-wire circuit, lead compensation can be provided in the software by a process value correction.			

Input for standard signals

Designation	Range	Meas. accuracy	Ambient temperature error
Voltage	0 – 10V, input resistance $R_E > 100k\Omega$	≤0.05%	100 ppm per °C
	-10 to +10V, input resistance $R_E > 100k\Omega$	≤0.05%	100 ppm per °C
	1 to + 1V, input resistance $R_E > 100k\Omega$	≤0.05%	100 ppm per °C
	0 to + 1V, input resistance $R_E > 100k\Omega$	≤0.05%	100 ppm per °C
	0 – 100mV, input resistance $R_E > 100k\Omega$	≤0.05%	100 ppm per °C
	-100 to +100mV, input resistance $R_E > 100k\Omega$	≤0.05%	100 ppm per °C
Current	4 – 20mA, voltage drop ≤ 1V	≤0.1%	100 ppm per °C
	0 – 20mA, voltage drop ≤ 1V	≤0.1%	100 ppm per °C
Potentiometer	100Ω min., 10kΩ max.		

Measurement circuit monitoring¹

Transducer	Over/underrange	Probe/lead short-circuit	Probe/lead break
Thermocouple	•	-	•
Resistance thermometer	•	•	•
Voltage 2 – 10V 0 – 10V	•	•	•
	•	-	-
Current 4 – 20mA 0 – 20mA	•	•	•
	•	-	-

• = recognised - = not recognised

1. In the event of an error, the outputs move to defined states (configurable).

Standard version

Outputs

Relay contact rating contact life contact protection circuit	changeover contact 3A at 250VAC resistive load 150 000 operations at rated load 56Ω/15nF between common-make/common-break		
Logic current limiting	0/5V 20mA	or	0/22V 30mA
Solid-state relay contact rating protection circuit	1A at 230V Varistor		
Voltage output signals load resistance	-10 to +10V/0 – 10V / 2 – 10V R _{load} 500Ω min.		
Current output signals load resistance	-20 to +20mA/0 – 20mA / 4 – 20mA R _{load} 450Ω max.		
Supply for 2-wire transmitter voltage current	22V 30mA		

Controller

Controller type	single-setpoint controller, double-setpoint controller, modulating controller, proportional controller, proportional controller with integral actuator driver
Controller structures	P/PD/PI/PID/I
A/D converter	resolution better than 15 bit
Sampling time	210msec

Electrical data

Supply (Switched mode power supply)	110 – 240V AC -15/+10%, 48 – 63Hz 20 – 30V AC/DC, 48 – 63Hz
Test voltages (type test)	to EN 61010, Part 1 overvoltage category II, pollution degree 2
Power consumption	10VA max. for Type 703570 7VA max. for Type 703575
Data backup	EEPROM
Electrical connection	At rear by screw terminals, conductor cross-section up to 2.5mm ² and core-end sleeve (length: 10mm)
Electromagnetic compatibility interference emission interference immunity	EN 61326-1 Class A - only for industrial use - to industrial requirements
Safety standards	to EN 60730-1 for Type 703570 to EN 61010-1 for Type 703575

Housing

Housing type	plastic housing for panel mounting to IEC 61554		
Dimensions in mm (for Type)	703575/1...	703575/2...	703570/0
Bezel	48 x 96 (portrait)	96 x 48 (landscape)	96 x 96
Depth behind panel	130	130	130
Panel cut-out	45 ^{+0.6} x 92 ^{+0.8}	92 ^{+0.8} x 45 ^{+0.6}	92 ^{+0.8} x 92 ^{+0.8}
Ambient/storage temperature range	-5 to 55 °C / -40 to +70 °C		
Climatic conditions	rel. humidity not exceeding 95% annual mean, no condensation		
Operating position	any		
Protection	to EN 60529, front IP65, rear IP20		
Weight (fully fitted)	approx. 420g	approx. 420g	approx. 730g

■ Standard version

Approvals/approval marks

Approval mark	Testing agency	Certificates/certification numbers	Test basis	valid for
ABS	American Bureau of shipping	Certificate No. 03-HG348501-PDA	ABS - Steel Vessel Rules	DICON 500
BV	Bureau Veritas	Certificate No. 22584/A0 BV File Number AP 4078 Product Code 2643H	B.V. Rules and Regulations for the Classification of Ships AUT-UMS, AUT-CCS, AUT-PORT, AUT-IMS	DICON 500
DIN	Deutsche Industrie Norm	Registernummer TR1117	DIN EN 14597	DICON 500
DNV	Det Norske Veritas	Certificate No. A-10489	DNV Rules for Ships Pt. 4 Ch. 9 - Control and Monitoring CLASSES Temperatur A Humidity B Vibration A EMC A	DICON 500
GL - Hardware GL - Software	Germanischer Lloyd	Certificate No. 15 694-00 HH	GL-Baumusterprüfung Kategorie C, EMC2	DICON 500
LR	Lloyd's Register	Certificate No. 00/20074 (E1)	LR Type Approval System Test Specification Number 1 Environmental categories ENV1 and ENV2	DICON 500
RINA	REGISTRO ITALIANO NAVALE	Certificate No. MAC82202CS1	RINA Type Approval System Rules for classification of ships - Part C-Machinery, systems and fire protection. - Ch. 3, Sect. 6, Table 1	DICON 500
c UL us	Underwriters Laboratories	E 201387	UL 61010-1 CAN/CSA-C22.2No.61010-1	DICON 400/500

Connection diagrams

Type 703570/0...

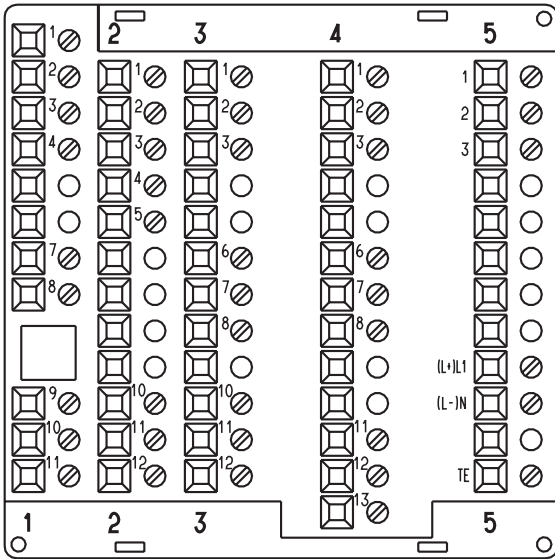

Interface

PROFIBUS DP

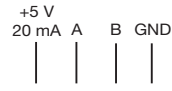

RS485/ER8



RS422

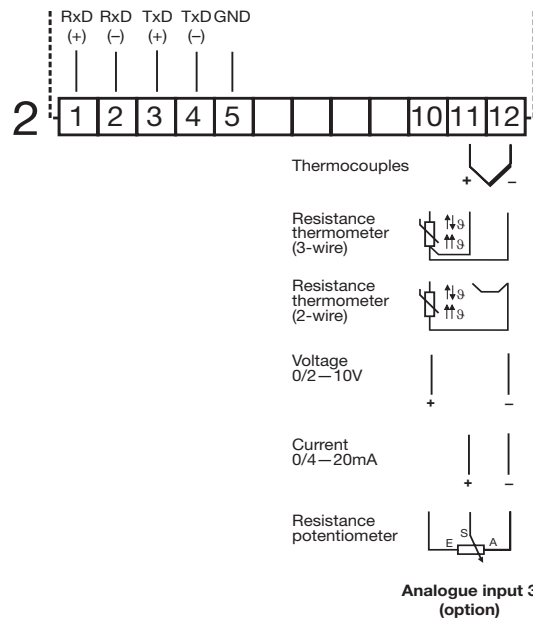
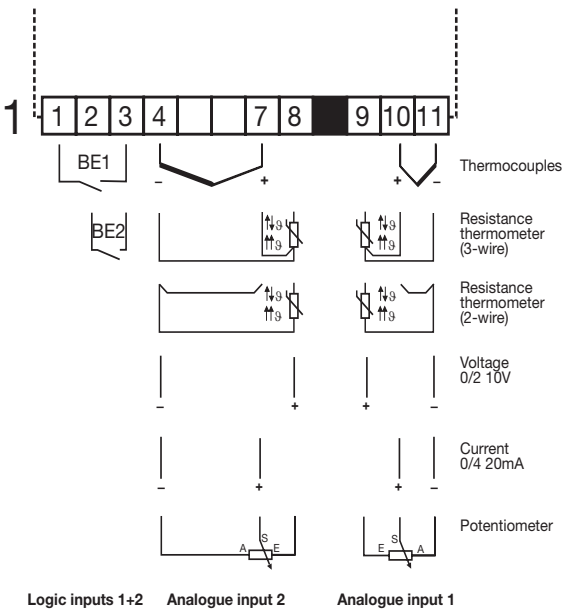
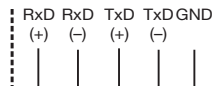

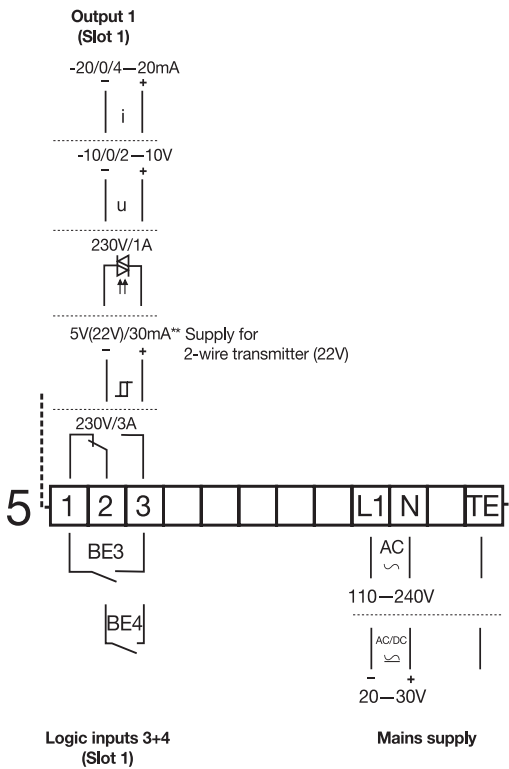
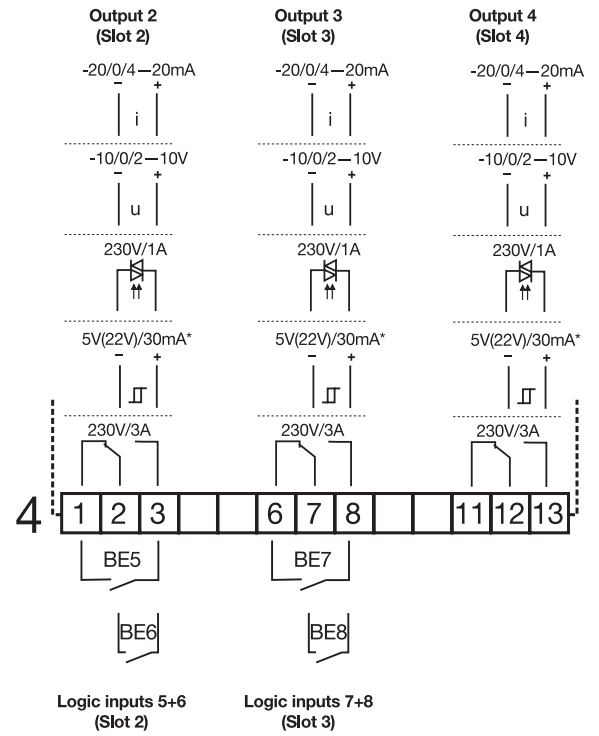
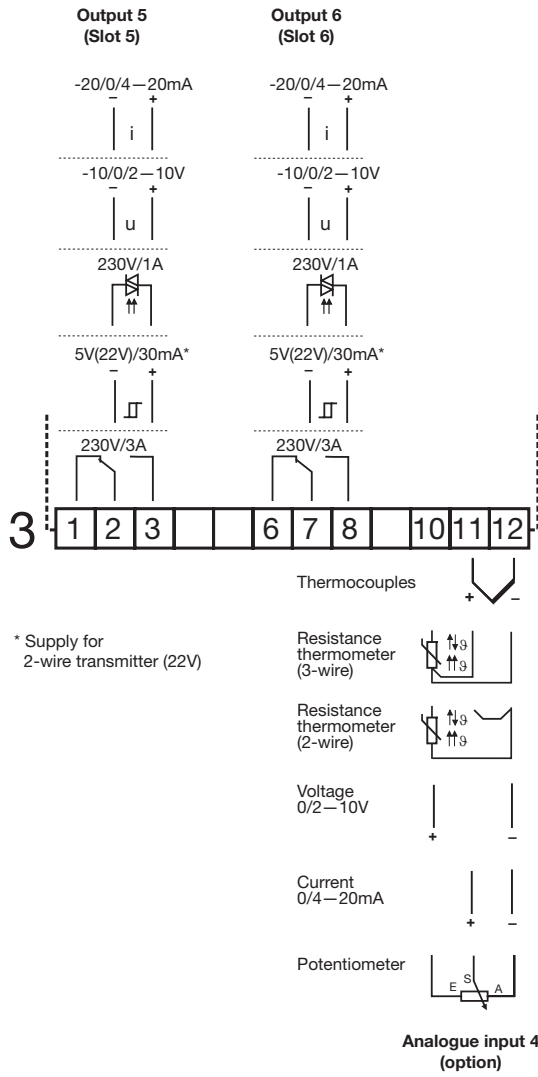

Type 703575/1... (portrait format) and Type 703575/2... (landscape format)

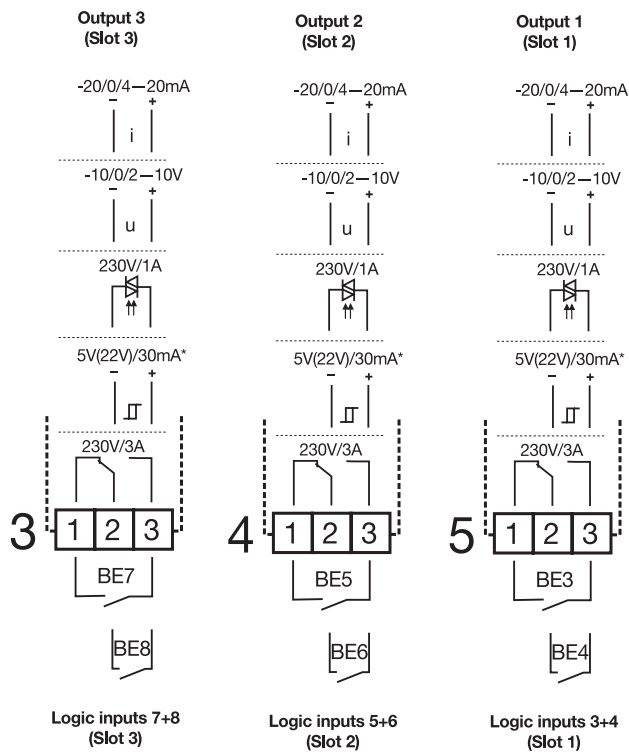
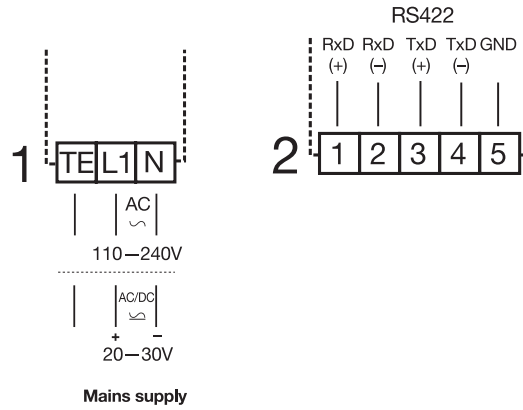
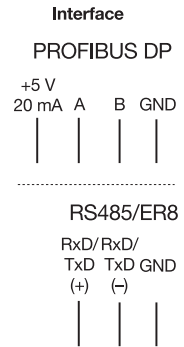
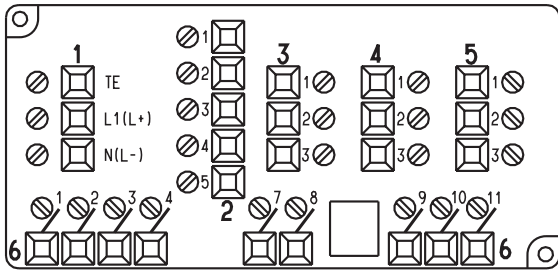

* supply for 2-wire transmitter (22V)

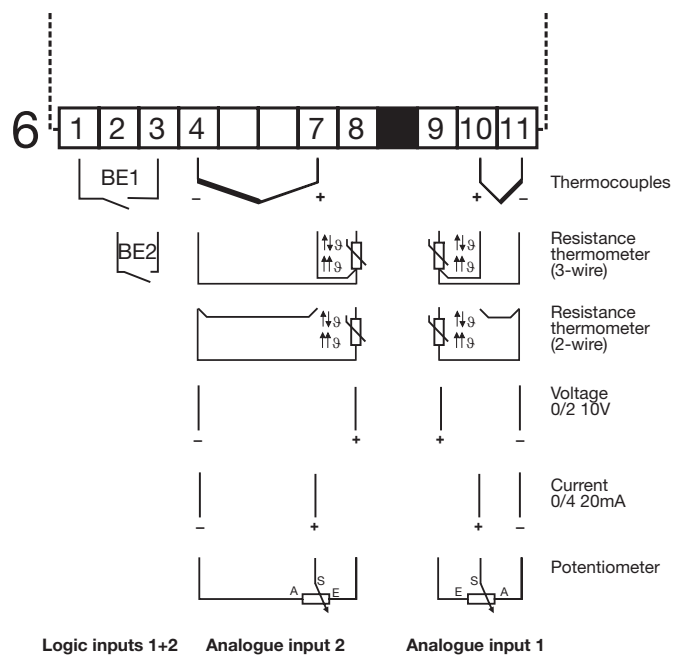

Dimensions

Type 703570/0...

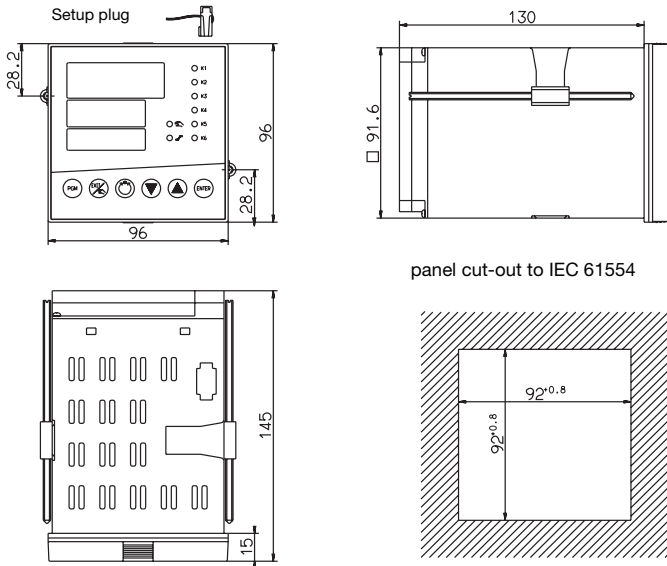

Type 703575/1... (portrait format)

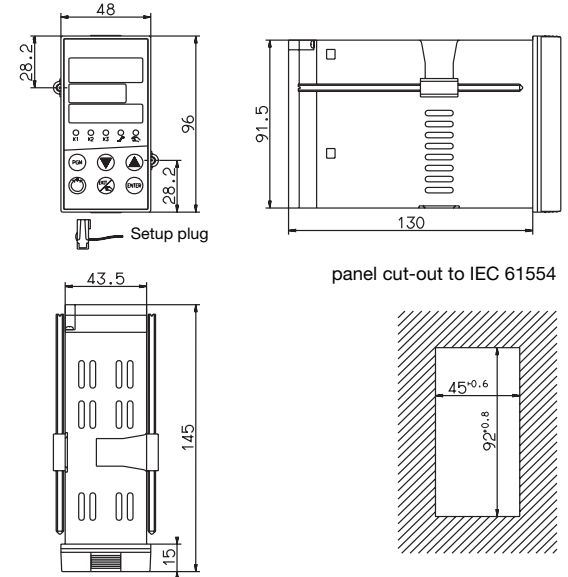

Type 703575/2... (landscape format)

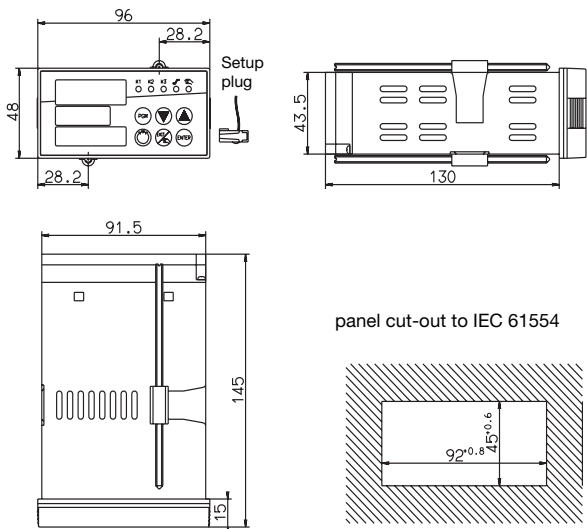

Edge-to-edge mounting		
Minimum distances of the panel cut-outs		
Type	horizontal	vertical
without setup plug:		
703570/0...	11 mm	30 mm
703575/1... (portrait)	11 mm	30 mm
703575/2... (landscape)	30 mm	11 mm
with setup plug:		
703570/0...	11 mm	65 mm
703575/1... (portrait)	11 mm	65 mm
703575/2... (landscape)	65 mm	11 mm

External module ER8/EL8

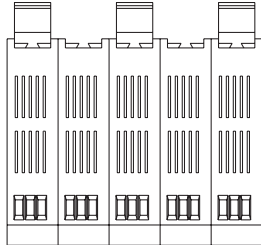
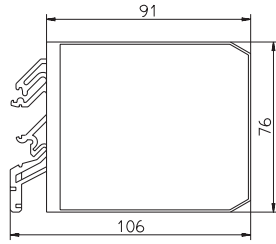
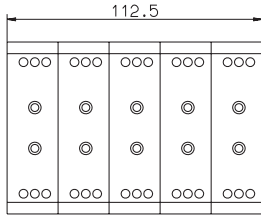

Accessories

External relay module ER8* (3A/230V) Supply 110 — 240V AC Sales No. 70/00405292
External relay module ER8* (3A/230V) Supply 20 — 53V DC/AC Sales No. 70/00405297
External logic module EL8* (0/12V) Supply 110 — 240V AC Sales No. 70/00439131
External logic module EL8* (0/12V) Supply 20 — 53V DC/AC Sales No. 70/00471459
PC interface for setup program with TTL/RS232 converter Sales No. 70/00301315
PC interface for setup program with USB/TTL converter, 2 adapters (socket, pins) Sales No. 70/00456352
Setup program including start-up software for Windows® 95/98/NT4.0 and 2000/XP/Vista Sales No. 70/00379085 Hardware requirements: - PC-486DX-2-100 - 16 Mbyte RAM - 15 Mbyte available on hard disk - CD-ROM drive - 1 free serial interface or USB interface

* The RS422/485 interface is required for operating the external module!

