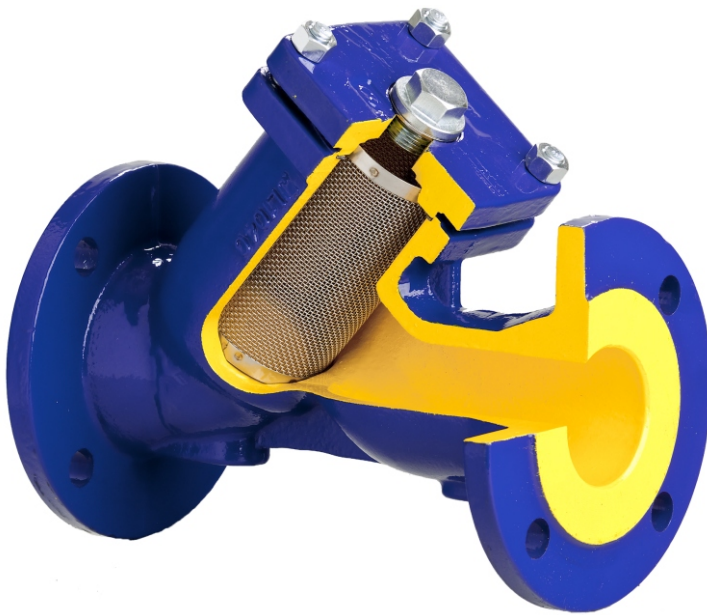




figure	821
ends form	flanged Y-type



STRAINER



body material	nominal pressure	nominal diameter	max. temperature
A grey cast iron	A 6 bar	DN 15-200	300°C
	C 16 bar	DN 15-400	300°C
C nodular cast iron	C 16 bar	DN 15-200	350°C
	D 25 bar	DN 15-200	350°C
D nodular cast iron	C 16 bar	DN 15-200	350°C
	D 25 bar	DN 15-200	350°C
F cast steel	E 40 bar	DN 15-200	400°C



correspond to the pressure equipment directive 97/23/EC marking CE for DN≥32

FEATURES

- screen made of stainless steel (from DN 50 with reinforced ring, from DN 150 with supporting basket)
- compact settlement
- environment-friendly
- cleaning of screen without disassembling
- face-to-face dimension according to EN 558-1 series 1
- flanges drilled according to EN 1092-1 for body material F
- flanges drilled according to EN 1092-2 for body material A,C,D
- closing tightness acc. EN -12266-1

APPLICATION

- hot and cold water plants
- steam plants
- industrial technologies
- heat and refrigerating engineering, air-conditioning

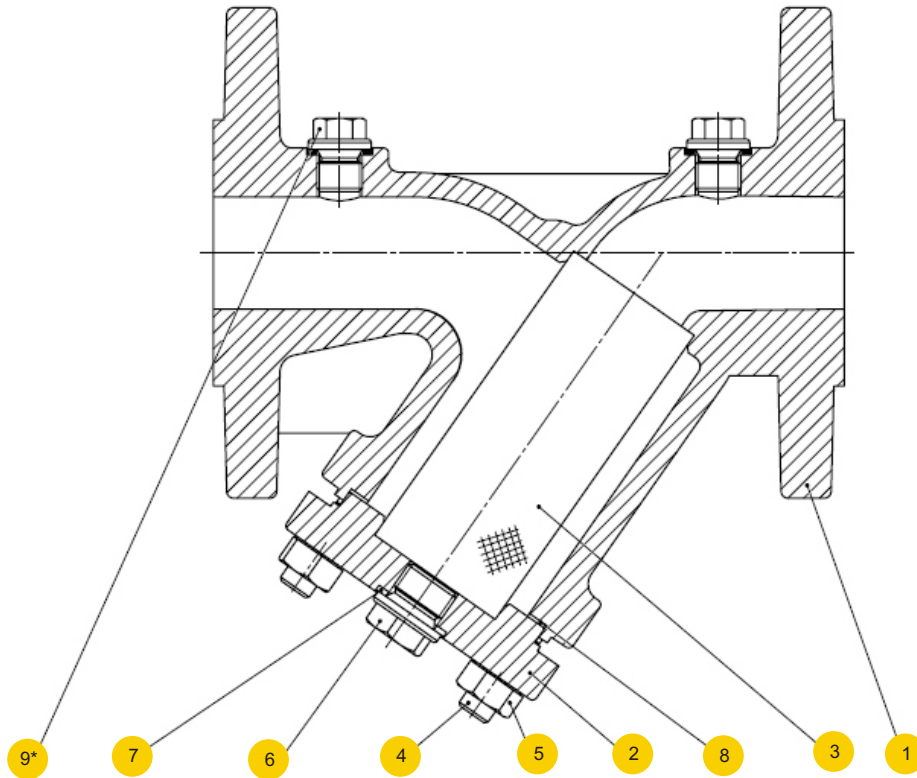
Data given can be changed without notice.

Edition 06/2011



figure **821**
ends form flanged
form Y-type

MATERIALS



	body material	A	C	D	F
1	body	EN – GJL-250 JL1040	EN – GJS-400-18 JS 1025	EN – GJS-500-7 JS 1050	GP240GH 1.0619
2	cover	EN – GJL-250 JL1040	EN – GJS-400-18 JS 1025	EN – GJS-500-7 JS 1050	GP240GH 1.0619
3	screen		X5CrNi18-10 1.4301		
3.1	supporting basket		X5CrNi18-10 1.4301 from DN ≥ 150		
4	studs	8.8-A2A	A2-70		25CrMo4
5	hexagon nut	8-A2A	A2-70		C35E
6	emptying screw		C35E		
7	plug gasket		A4 1.4571		
8	cover gasket		CrNiSt - Graphite		
9	plug*, **		C35E		
	max. temperature	300°C	350°C		400°C

* position of the plug don't refer to PN 6

** plugs on client's request

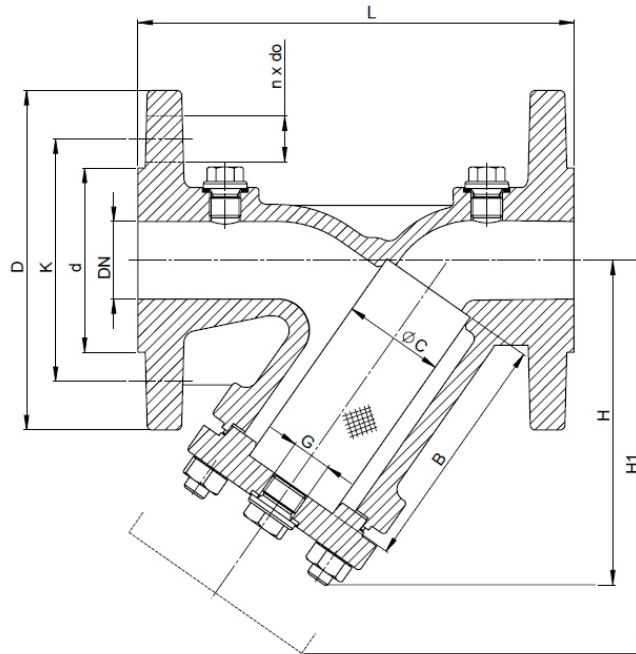
Data given can be changed without notice.

Edition 06/2011



figure 821
ends form flanged Y-type

DIMENSIONS



DN	PN 6					PN 16				PN 25				PN 40				H	H1	G	PN 6	PN 16	PN 25	PN 40	Kv	C	B
	L	D	d	K	nxdo	D	d	K	nxdo	D	d	K	nxdo	D	d	K	nxdo										
mm																			kg				m ³ /h	mm			
15	130	80	38	55	4x11	95	46	65	4x14	95	46	65	4x14	95	45	65	4x14	90	135	3/8	2,2	2,6	2,6	2,7	5,7	23	56
20	150	90	48	65	4x11	105	56	75	4x14	105	56	75	4x14	105	58	75	4x14	100	150	3/8	2,8	3,0	3,0	3,6	10,4	28	68
25	160	100	58	75	4x11	115	65	85	4x14	115	65	85	4x14	115	68	85	4x14	115	180	3/4	3,9	4,3	4,3	4,5	16,4	36	82
32	180	120	69	90	4x14	140	76	100	4x19	140	76	100	4x19	140	78	100	4x18	135	215	3/4	5,7	6,8	6,8	6,3	27,3	42	98
40	200	130	78	100	4x14	150	84	110	4x19	150	84	110	4x19	150	88	110	4x18	150	240	1	7,3	8,8	9,0	8,7	42,0	50	114
50	230	140	88	110	4x14	165	99	125	4x19	165	99	125	4x19	165	102	125	4x18	155	250	1	8,4	11,0	11,0	11,0	64,7	61,5	119
65	290	160	108	130	4x14	185	118	145	4x19	185	118	145	8x19	185	122	145	8x18	175	285	1	13,5	14,6	16,8	18,5	98,0	78,5	134
80	310	190	124	150	4x19	200	132	160	8x19	200	132	160	8x19	200	138	160	8x18	205	330	1	17,7	18,6	19,5	23,5	149	89,5	149
100	350	210	144	170	4x19	220	156	180	8x19	235	156	190	8x23	235	162	190	8x22	275	365	1 1/2	25,3	27,0	29,6	33,0	234	109,5	169
125	400	240	174	200	8x19	250	184	210	8x19	270	184	220	8x28	270	188	220	8x26	325	425	1 1/2	37,5	38,5	42,5	54,0	376	137,5	199
150	480	265	199	225	8x19	285	211	240	8x23	300	211	250	8x28	300	218	250	8x26	397	480	1 1/2	49,0	54,5	56,0	75,0	454	160	224
200	600	320	254	280	8x19	340	266	295	12x23	360	274	310	12x28	375	285	320	12x30	535	610	1 1/2	98,0	110,0	110,0	137,0	853	210	284
250	730	-	-	-	-	405	319	355	12x28	-	-	-	-	-	-	-	-	670	915	1 1/2	-	165,0	-	-	1104	258	434
300	850	-	-	-	-	460	370	410	12x28	-	-	-	-	-	-	-	-	680	1110	1 1/2	-	285,0	-	-	1450	308	555
350	980	-	-	-	-	520	429	470	16x28	-	-	-	-	-	-	-	-	755	1200	1 1/2	-	373,0	-	-	1800	365	640
400	1100	-	-	-	-	580	480	525	16x31	-	-	-	-	-	-	-	-	835	1320	1 1/2	-	540	-	-	2200	415	695

Data given can be changed without notice.

Edition 06/2011



figure	821
ends form	flanged Y-type

SCREENS*

screen	type	DN	mash	meshes screen	wykonanie/ performance
standard	F45	10-50	1,0	45	50
	F28	65-80	1.25	28	49
	F15	100-400	1.6	15	43
other performance	screen F100 (0,6), F200 (0,5), F300 (0,4), F400 (0,32), F600 (0,2)				

* type with magnetic cartridge on client's request

COVER GASKET DIMENSIONS

DN	15		20		25		32		40		50		65		80		100		125		150		200	
	Dz	Dw	Dz	Dw	Dz	Dw	Dz	Dw	Dz	Dw	Dz	Dw	Dz	Dw	Dz	Dw	Dz	Dw	Dz	Dw	Dz	Dw	Dz	Dw
PN 6	46	36	46	36	56	46	68	56	79	68	87	75	112	100	122	110	151	135	186	170	206	190	300	275
PN 16	46	36	46	36	56	46	68	56	79	68	87	75	102	90	122	110	135	120	170	151	195	175	270*	245*
PN 25	46	36	46	36	56	46	68	56	79	68	87	75	102	90	122	110	135	120	170	151	195	175	300	275
PN 40	46	36	46	36	56	46	68	56	79	68	87	75	102	90	122	110	135	120	170	151	195	175	270	245

* for grey cast iron, for nodular cast iron = 300/275

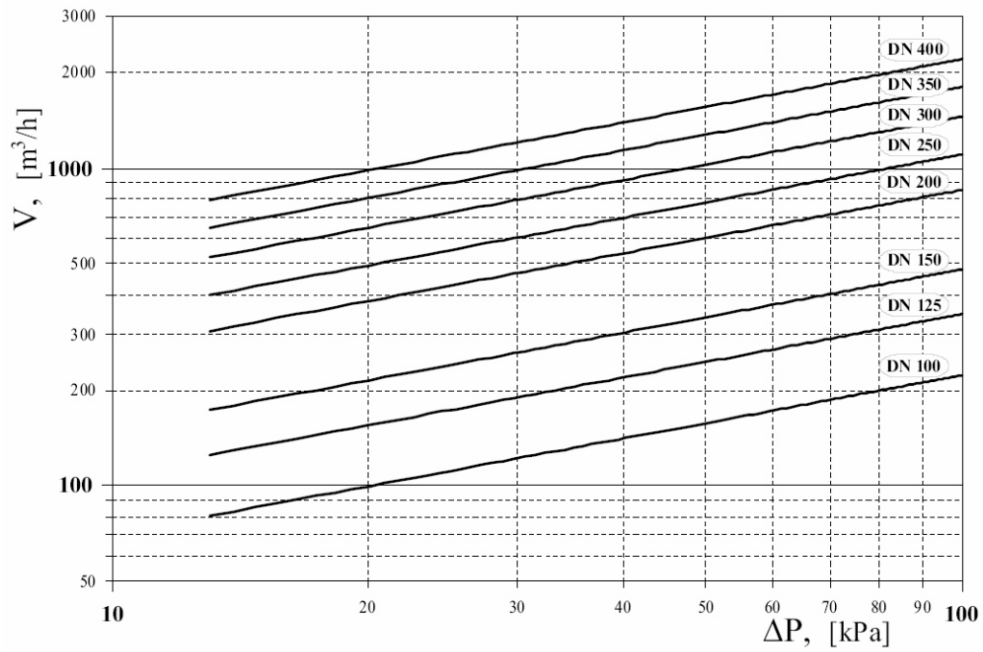
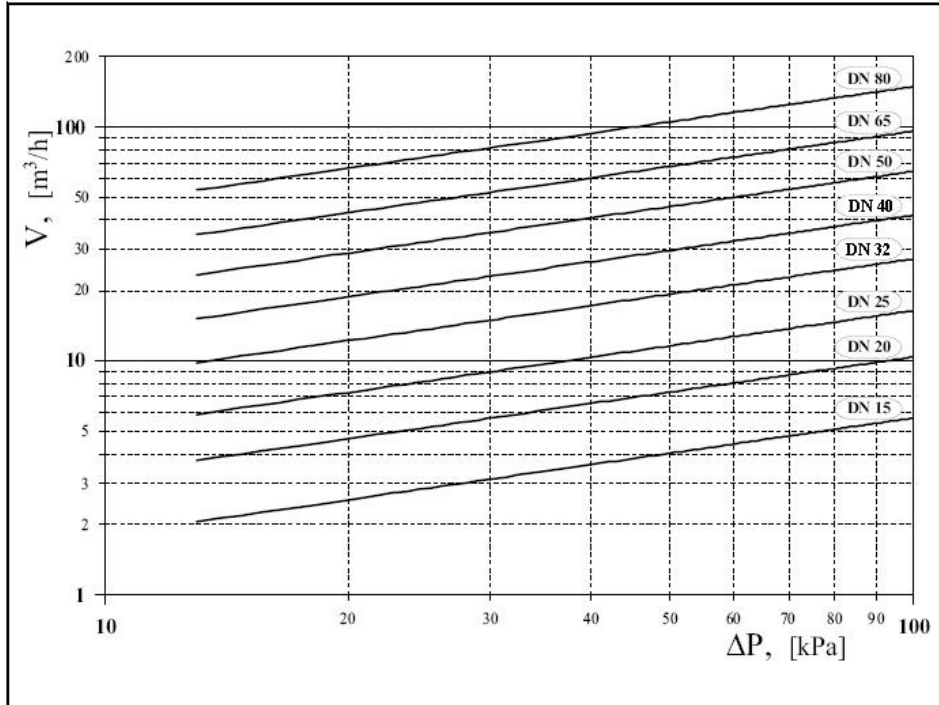
DN	250		300		350		400	
	Dz	Dw	Dz	Dw	Dz	Dw	Dz	Dw
PN 16	300	275	375	350	425	390	475	440

gasket's thickness = 1 mm



figure **821**
ends flanged
form Y-type

HYDRAULIC CHARACTERISTIC

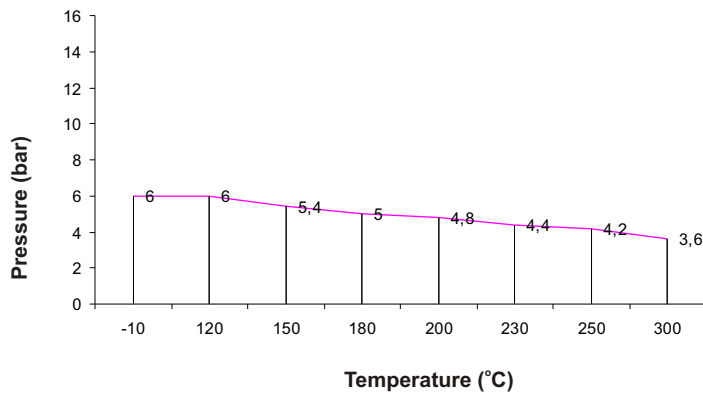


Data given can be changed without notice.

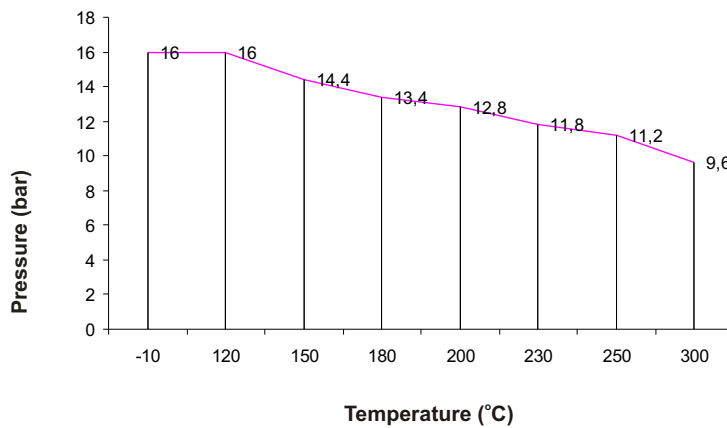
Edition 06/2011



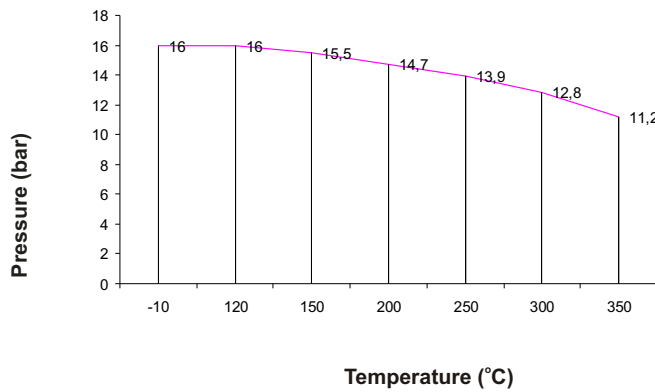
PRESSURE-TEMPERATURE RATINGS



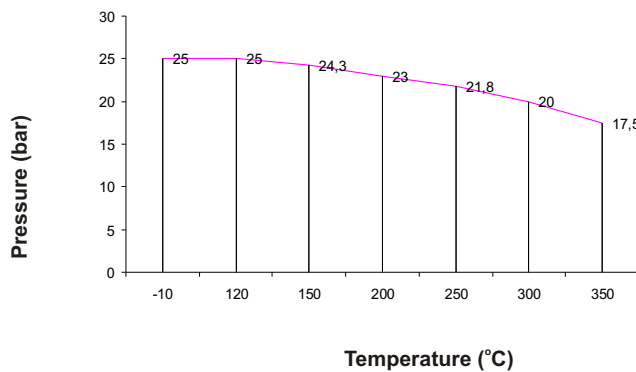
Allowed working conditions range
PN 6 EN-GJL-250



Allowed working conditions range
PN 16 EN-GJL-250



Allowed working conditions range
PN 16 EN-GJS-400-18-LT

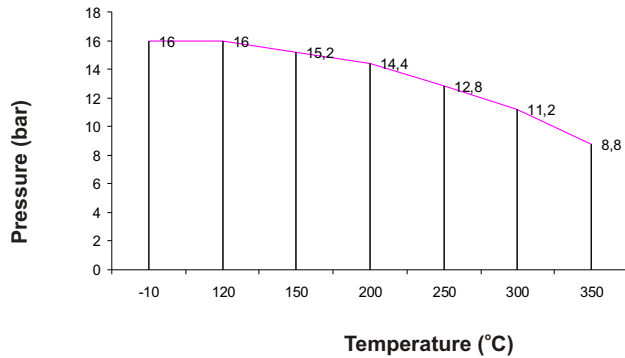


Allowed working conditions range
PN 25 EN-GJS-400-18-LT

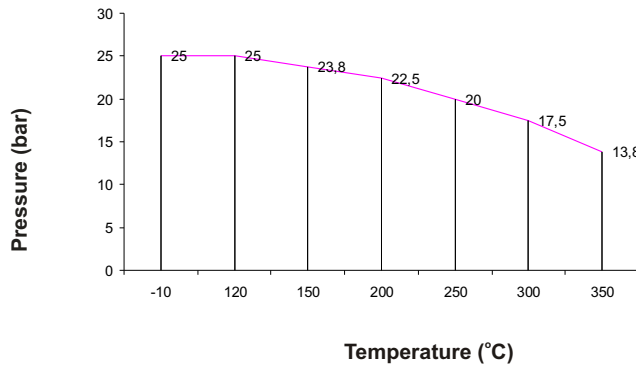


figure **821**
ends form flanged Y-type

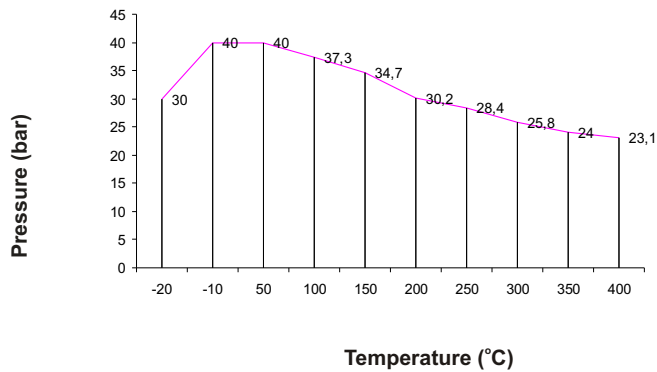
PRESSURE-TEMPERATURE RATINGS



Allowed working conditions range
PN 16 EN-GJS-500-7



Allowed working conditions range
PN 25 EN-GJS-500-7



Allowed working conditions range
PN 40 GP24GH 1.0619



figure 821
ends form flanged Y-type

TYPES

figure	body material	nominal diameter DN	nominal pressure PN	type
821	A grey cast iron EN-GJL-250	15-50 mm	A 6bar	50 * mesh 1,00 mm, 45 mesh/cm2 Tmax 300 °C
		65-80 mm	A 6bar	49 * mesh 1,25 mm, 28 mesh/cm2 Tmax 300 °C
		100-200 mm	A 6bar	43 * mesh 1,60 mm, 15 mesh/cm2 Tmax 300 °C
		15-200 mm	A 6bar	44 mesh 0,63 mm, 100 mesh/cm2 Tmax 300 °C
		15-200 mm	A 6bar	45 * mesh 0,50 mm, 200 mesh/cm2 Tmax 300 °C
		15-200 mm	A 6bar	46 * mesh 0,40 mm, 300 mesh/cm2 Tmax 300 °C
		15-200 mm	A 6bar	47 * mesh 0,32 mm, 400 mesh/cm2 Tmax 300 °C
		15-200 mm	A 6bar	48 * mesh 0,20 mm, 600 mesh/cm2 Tmax 300 °C
		15-50 mm	C 16bar	50 * mesh 1,00 mm, 45 mesh/cm2 Tmax 300 °C
		65-80 mm	C 16bar	49 * mesh 1,25 mm, 28 mesh/cm2 Tmax 300 °C
		100-400 mm	C 16bar	43 mesh 1,60 mm, 15 mesh/cm2 Tmax 300 °C
		15-400 mm	C 16bar	44 * mesh 0,63 mm, 100 mesh/cm2 Tmax 300 °C
		15-400 mm	C 16bar	45 * mesh 0,50 mm, 200 mesh/cm2 Tmax 300 °C
		15-400 mm	C 16bar	46 * mesh 0,40 mm, 300 mesh/cm2 Tmax 300 °C
		15-400 mm	C 16bar	47 * mesh 0,32 mm, 400 mesh/cm2 Tmax 300 °C
		15-400 mm	C 16bar	48 * mesh 0,20 mm, 600 mesh/cm2 Tmax 300 °C
		15-50 mm	C 16bar	70 * mesh 1,00 mm, 45 mesh/cm2 * with magnetic cartridge Tmax 300 °C
		65-80 mm	C 16bar	69 mesh 1,25 mm, 28 mesh/cm2 * with magnetic cartridge Tmax 300 °C
		100-400 mm	C 16bar	63 mesh 1,60 mm, 15 mesh/cm2 * with magnetic cartridge Tmax 300 °C

Data given can be changed without notice.

Edition 06/2011



figure	821
ends form	flanged Y-type

TYPES

figure	body material	nominal diameter DN	nominal pressure PN	type
821	A grey cast iron EN-GJL-250	15-50 mm	C 16bar	50-D Tmax 80 °C * mesh 1,00 mm, 45 mesh/cm2 * epoxy paint
		65-80 mm	C 16bar	49-D Tmax 80 °C * mesh 1,25 mm, 28 mesh/cm2 * epoxy paint
		100-200 mm	C 16bar	43-D Tmax 80 °C * mesh 1,60 mm, 15 mesh/cm2 * epoxy paint
		15-200 mm	C 16bar	44-D Tmax 80 °C * mesh 0,63 mm, 100 mesh/cm2 * epoxy paint
		15-200 mm	C 16bar	45-D Tmax 80 °C * mesh 0,50 mm, 200 mesh/cm2 * epoxy paint
		15-200 mm	C 16bar	46-D Tmax 80 °C * mesh 0,40 mm, 300 mesh/cm2 * epoxy paint
		15-200 mm	C 16bar	47-D Tmax 80 °C * mesh 0,32 mm, 400 mesh/cm2 * epoxy paint
		15-200 mm	C 16bar	48-D Tmax 80 °C * mesh 0,20 mm, 600 mesh/cm2 * epoxy paint



figure	821
ends form	flanged Y-type

TYPES

figure	body material	nominal diameter DN	nominal pressure PN	type
821	C nodular cast iron EN-GJS-400-18-LT	15-50 mm	C 16bar	50 * mesh 1,00 mm, 45 mesh/cm2 Tmax 350 °C
		65-80 mm	C 16bar	49 * mesh 1,25 mm, 28 mesh/cm2 Tmax 350 °C
		100-200 mm	C 16bar	43 * mesh 1,60 mm, 15 mesh/cm2 Tmax 350 °C
		15-200 mm	C 16bar	44 * mesh 0,63 mm, 100 mesh/cm2 Tmax 350 °C
		15-200 mm	C 16bar	45 * mesh 0,50 mm, 200 mesh/cm2 Tmax 350 °C
		15-200 mm	C 16bar	46 * mesh 0,40 mm, 300 mesh/cm2 Tmax 350 °C
		15-200 mm	C 16bar	47 * mesh 0,32 mm, 400 mesh/cm2 Tmax 350 °C
		15-200 mm	C 16bar	48 * mesh 0,20 mm, 600 mesh/cm2 Tmax 350 °C
		15-50 mm	D 25bar	50 * mesh 1,00 mm, 45 mesh/cm2 Tmax 350 °C
		65-80 mm	D 25bar	49 * mesh 1,25 mm, 28 mesh/cm2 Tmax 350 °C
		100-200 mm	D 25bar	43 * mesh 1,60 mm, 15 mesh/cm2 Tmax 350 °C
		15-200 mm	D 25bar	44 * mesh 0,63 mm, 100 mesh/cm2 Tmax 350 °C
		15-200 mm	D 25bar	45 * mesh 0,50 mm, 200 mesh/cm2 Tmax 350 °C
		15-200 mm	C 25bar	46 * mesh 0,40 mm, 300 mesh/cm2 Tmax 350 °C
		15-200 mm	D 25bar	47 * mesh 0,32 mm, 400 mesh/cm2 Tmax 350 °C
		15-200 mm	D 25bar	48 * mesh 0,20 mm, 600 mesh/cm2 Tmax 350 °C

Data given can be changed without notice.

Edition 06/2011



figure	821
ends form	flanged Y-type

TYPES

figure	body material	nominal diameter DN	nominal pressure PN	type
821	D nodular cast iron EN-GJS-500-7	15-50 mm	C 16bar	50 * mesh 1,00 mm, 45 mesh/cm2 Tmax 350 °C
		65-80 mm	C 16bar	49 * mesh 1,25 mm, 28 mesh/cm2 Tmax 350 °C
		100-200 mm	C 16bar	43 * mesh 1,60 mm, 15 mesh/cm2 Tmax 350 °C
		15-200 mm	C 16bar	44 * mesh 0,63 mm, 100 mesh/cm2 Tmax 350 °C
		15-200 mm	C 16bar	45 * mesh 0,50 mm, 200 mesh/cm2 Tmax 350 °C
		15-200 mm	C 16bar	46 * mesh 0,40 mm, 300 mesh/cm2 Tmax 350 °C
		15-200 mm	C 16bar	47 * mesh 0,32 mm, 400 mesh/cm2 Tmax 350 °C
		15-200 mm	C 16bar	48 * mesh 0,20 mm, 600 mesh/cm2 Tmax 350 °C
		15-50 mm	D 25bar	50 * mesh 1,00 mm, 45 mesh/cm2 Tmax 350 °C
		65-80 mm	D 25bar	49 * mesh 1,25 mm, 28 mesh/cm2 Tmax 350 °C
		100-200 mm	D 25bar	43 * mesh 1,60 mm, 15 mesh/cm2 Tmax 350 °C
		15-200 mm	D 25bar	44 * mesh 0,63 mm, 100 mesh/cm2 Tmax 350 °C
		15-200 mm	D 25bar	45 * mesh 0,50 mm, 200 mesh/cm2 Tmax 350 °C
		15-200 mm	C 25bar	46 * mesh 0,40 mm, 300 mesh/cm2 Tmax 350 °C
		15-200 mm	D 25bar	47 * mesh 0,32 mm, 400 mesh/cm2 Tmax 350 °C
		15-200 mm	D 25bar	48 * mesh 0,20 mm, 600 mesh/cm2 Tmax 350 °C

Data given can be changed without notice.

Edition 06/2011



figure	821
ends form	flanged Y-type

TYPES

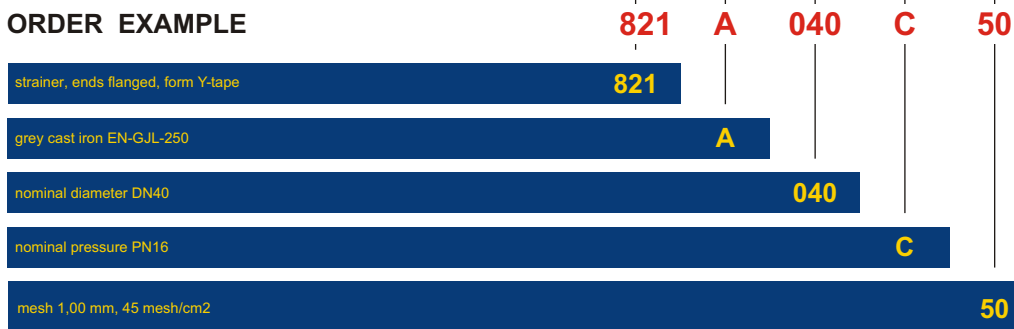
figure	body material	nominal diameter DN	nominal pressure PN	type
821	F cast steel GP240GH 1.0619	15-50 mm	E 40bar	50 * mesh 1,00 mm, 45 mesh/cm2 Tmax 400 °C
		65-80 mm	E 40bar	49 * mesh 1,25 mm, 28 mesh/cm2 Tmax 400 °C
		100-200 mm	E 40bar	43 * mesh 1,60 mm, 15 mesh/cm2 Tmax 400 °C
		15-200 mm	E 40bar	44 * mesh 0,63 mm, 100 mesh/cm2 Tmax 400 °C
		15-200 mm	E 40bar	45 * mesh 0,50 mm, 200 mesh/cm2 Tmax 400 °C
		15-200 mm	E 40bar	46 * mesh 0,40 mm, 300 mesh/cm2 Tmax 400 °C
		15-200 mm	E 40bar	47 * mesh 0,32 mm, 400 mesh/cm2 Tmax 400 °C
		15-200 mm	E 40bar	48 * mesh 0,20 mm, 600 mesh/cm2 Tmax 400 °C

ORDERING

To place an order please use our product number (index)



ORDER EXAMPLE



Data given can be changed without notice.

Edition 06/2011