

JUMO GmbH & Co. KG
 Delivery address: Mackenrodtstraße 14,
 36039 Fulda, Germany
 Postal address: 36035 Fulda, Germany
 Phone: +49 661 6003-0
 Fax: +49 661 6003-607
 e-mail: mail@jumo.net
 Internet: www.jumo.net

JUMO Instrument Co. Ltd.
 JUMO House
 Temple Bank, Riverway
 Harlow, Essex CM20 2DY, UK
 Phone: +44 1279 635533
 Fax: +44 1279 635262
 e-mail: sales@jumo.co.uk
 Internet: www.jumo.co.uk

JUMO Process Control, Inc.
 8 Technology Boulevard
 Canastota, NY 13032, USA
 Phone: 315-697-JUMO
 1-800-554-JUMO
 Fax: 315-697-5867
 e-mail: info@jumo.us
 Internet: www.jumo.us



JUMO LOGOSCREEN 500 cf

Entry-level Paperless Recorder with CompactFlash card and life-cycle data management

Brief description

The appearance of the LOGOSCREEN 500 cf is dominated by a 5-inch color display, in which the measurement data can be displayed in a vertical direction, similar to ordinary chart recorders. But unlike ordinary recorders, the LOGOSCREEN 500 cf does not need any chart paper for recording. Measurement data are stored electronically, and are available for evaluation on the spot as well as in the PC.

The integrated life-cycle data management ensures fast traceability of process data referred to specific installations.

According to choice, the LOGOSCREEN 500 cf can be fitted with 3 or 6 electrically isolated measurement inputs. The recorder can be programmed from eight keys, or by using a PC via a CompactFlash card or one of the interfaces.

The bezel size is 144mm x 144mm, depth behind panel 214mm.



Type 706510/...

Block structure

3/6 analog inputs

Thermocouple
 RTD
 Voltage
 Current
 (inputs are electrically isolated from one another)

Power supply

110 - 240V AC
 or
 20 - 53V AC/DC

Features

5" STN color screen
 320 x 240 pixels, 27 colors

CompactFlash card
 ≤ 2GB for transfer of measurements and configuration of paperless recorder

CPU card
 with main memory and measurement data memory (FLASH memory) for approx. 350 000 measurements



Extra codes

4 binary inputs
 their states can be graphically displayed

3 relays
 changeover (SPDT)
 3A, 230V

RS232/RS485 or Ethernet interface
 for process and configuration data

Math and logic module

Counters and integrators

Software (accessory)

Setup program
 for configuration

Evaluation software
 for representation and evaluation of measurement data

Communication software
 for automatic data readout (also via modem)

Key features

- Measurement data presented numerically as vertical diagrams (with scaling, numerical display, or as a bar graph)
- Presentation of event traces such as "Binary inputs"
- On-site availability of measurements in the FLASH memory
- Measurement data are retained, even after a power interruption
- Saving of data sets on the CompactFlash card
- Instrument configuration through the keys or the setup program (CompactFlash card or interface)
- Evaluation of archived data with PC evaluation program
- Search function for history analysis
- Adaptation of the memory cycles to the specific process, using normal, time-of-day and event operation
- Freely configurable inputs
- Internal sampling rate 250msec for 3 or 6 analog inputs, minimum storage cycle 1 sec
- Counters and integrators (6 channels)
- Math and logic module (6 channels)
- integrated web server

Approvals



Technical data

Analog inputs

Input for DC voltage, DC current

Basic range	Accuracy	Input resistance
-20 to +70mV	±80µV	$R_{IN} \geq 1 \text{ M}\Omega$
-3 to +105mV	±100µV	$R_{IN} \geq 1 \text{ M}\Omega$
-10 to +210mV	±240µV	$R_{IN} \geq 1 \text{ M}\Omega$
-0.5 to +12V	±6mV	$R_{IN} \geq 470 \text{ k}\Omega$
-0.05 to +1.2V	±1mV	$R_{IN} \geq 470 \text{ k}\Omega$
-1.2 to +1.2V	±2mV	$R_{IN} \geq 470 \text{ k}\Omega$
-10 to +12V	±12mV	$R_{IN} \geq 470 \text{ k}\Omega$
Shortest span	5mV	
Range start/end	freely programmable within the limits in 0.01 mV steps	
-2 to +22mA	±20µA	burden voltage ≤ 1V
-22 to +22mA	±44µA	burden voltage ≤ 1V
Shortest span	0.5mA	
Range start/end	freely programmable within the limits in 0.01 mA steps	
Overrange / underrange	according to NAMUR NE 43	
Sampling cycle	3 or 6 channels 250msec	
Input filter	2nd order digital filter; filter constant adjustable from 0 to 10.0sec	
Test voltage for electrical isolation	350V (via optocoupler)	
Resolution	> 14 bit	

Thermocouple

Designation	Type	Standard	Meas. range	Accuracy ¹
Fe-Con	L	DIN 43 710	-200 to +900°C	±0.1 %
Fe-Con	J	EN 60 584	-210 to +1200°C	±0.1 % from -100°C
Cu-Con	U	DIN 43 710	-200 to +600°C	±0.1 % from -150°C
Cu-Con	T	EN 60 584	-270 to +400°C	±0.15 % from -150°C
NiCr-Ni	K	EN 60 584	-270 to +1372°C	±0.1 % from -80°C
NiCr-Con	E	EN 60 584	-270 to +1000°C	±0.1 % from -80°C
NiCrSi-NiSi	N	EN 60 584	-270 to +1300°C	±0.1 % from -80°C
Pt10Rh-Pt	S	EN 60 584	-50 to +1768°C	±0.15 % from 0°C
Pt13Rh-Pt	R	EN 60 584	-50 to +1768°C	±0.15 % from 0°C
Pt30Rh-Pt6Rh	B	EN 60 584	0 to 1820°C	±0.15 % from 400°C
W3Re/W25Re	D		0 to 2400°C	±0.15 % from 500°C
W5Re/W26Re	C		0 to 2320°C	±0.15 % from 500°C
Chromel-Copel		GOST R 8.585-2001	-200 to +800°C	±0.1 %
Shortest span			Type L, J, U, T, K, E, N, chromel-copel: Type S, R, B, D, C:	100°C 500°C
Range start/end	freely programmable within the limits, in 0.1°C steps			
Cold junction	Pt100 internal or thermostat external constant			
Cold junction accuracy (internal)	± 1°C			
Cold junction temperature (external)	-50 to +150°C, adjustable			
Sampling cycle	3 or 6 channels, 250msec			
Input filter	2nd order digital filter; filter constant adjustable from 0 to 10.0sec			
Test voltage for electrical isolation	350V (via optocoupler)			
Resolution	> 14 bit			
Special features	also programmable in °F			

¹ The accuracy refers to the maximum measuring range. The accuracy is reduced with short spans.

RTD

Designation	Standard	Connection circuit	Meas. range	Accuracy	Measuring current
Pt100	EN 60 751 (TC = $3.85 \cdot 10^{-3} \text{ 1/}^\circ\text{C}$)	2/3-wire	-200 to +100°C	±0.5°C	500µA
		2/3-wire	-200 to +850°C	±0.8°C	250µA
		4-wire	-200 to +100°C	±0.5°C	500µA
		4-wire	-200 to +850°C	±0.5°C	250µA
Pt100	JIS 1604 (TC = $3.917 \cdot 10^{-3} \text{ 1/}^\circ\text{C}$)	2/3-wire	-200 to +100°C	±0.5°C	500µA
		2/3-wire	-200 to +650°C	±0.8°C	250µA
		4-wire	-200 to +100°C	±0.5°C	500µA
		4-wire	-200 to +650°C	±0.5°C	250µA
Pt100	GOST 6651-94 A.1 (TC = $3.91 \cdot 10^{-3} \text{ 1/}^\circ\text{C}$)	2/3-wire	-200 to +100°C	±0.5°C	500µA
		2/3-wire	-200 to +850°C	±0.8°C	250µA
		4-wire	-200 to +100°C	±0.5°C	500µA
		4-wire	-200 to +850°C	±0.5°C	250µA
Pt500	EN 60 751 (TC = $3.85 \cdot 10^{-3} \text{ 1/}^\circ\text{C}$)	2/3-wire	-200 to +100°C	±0.5°C	250µA
		2/3-wire	-200 to +850°C	±0.8°C	250µA
		4-wire	-200 to +100°C	±0.5°C	250µA
		4-wire	-200 to +850°C	±0.5°C	250µA
Pt1000	EN 60 751 (TC = $3.85 \cdot 10^{-3} \text{ 1/}^\circ\text{C}$)	2/3-wire	-200 to +100°C	±0.5°C	500µA
		2/3-wire	-200 to +850°C	±0.8°C	250µA
		4-wire	-200 to +100°C	±0.5°C	500µA
		4-wire	-200 to +850°C	±0.5°C	250µA
Ni100	DIN 43 760 (TC = $6.18 \cdot 10^{-3} \text{ 1/}^\circ\text{C}$)	2/3-wire	-60 to +180°C	±0.4°C	500µA
		4-wire	-60 to +180°C	±0.4°C	500µA
Pt50	ST RGW 1057 1985 (TC = $3.91 \cdot 10^{-3} \text{ 1/}^\circ\text{C}$)	2/3-wire	-200 to +100°C	±0.5°C	500µA
		2/3-wire	-200 to +1100°C	±0.9°C	250µA
		4-wire	-200 to +100°C	±0.5°C	500µA
		4-wire	-200 to +1100°C	±0.6°C	250µA
Cu 50	GOST 6651-94 A.3 (TC = $4.28 \cdot 10^{-3} \text{ 1/}^\circ\text{C}$)	2/3-wire	-50 to +100°C	±0.5°C	500µA
		2/3-wire	-50 to +200°C	±0.9°C	250µA
		4-wire	-50 to +100°C	±0.5°C	500µA
		4-wire	-50 to +200°C	±0.6°C	250µA
Cu100	GOST 6651-94 A.4 (TC = $4.26 \cdot 10^{-3} \text{ 1/}^\circ\text{C}$)	2/3-wire	-50 to +200°C	±0.5°C	500µA
		4-wire	-50 to +200°C	±0.5°C	500µA
Connection circuit	2-, 3-, or 4-wire circuit				
Shortest span	15°C				
Sensor lead resistance	max. 30 Ω per conductor for 3-wire/4-wire circuit max. 10 Ω per conductor for 2-wire circuit				
Range start/end	freely programmable within the limits in 0.1°C steps				
Sampling cycle	3 or 6 channels, 250msec				
Input filter	2nd order digital filter; filter constant adjustable from 0 to 10sec				
Test voltage for electrical isolation	350V (via optocoupler)				
Resolution	> 14 bit				

Transducer short circuit/break

	Short circuit ¹	Break ¹
Thermocouple	not detected	detected
RTD	detected	detected
Voltage ≤ 210mV	not detected	detected
Voltage > 210mV	not detected	not detected
Current	not detected	not detected

¹ Programmable reaction of device, e.g. trigger an alarm

Binary inputs (extra code)

Quantity	4, to DIN 19 240; 1Hz max., 32V max.
Level	logic "0": -3 to +5V, logic "1": 12 – 30V
Sampling cycle (binary inputs, without counter function)	1 sec
Count frequency (binary inputs, with counter function)	30Hz max.
Auxiliary voltage (output)	24V ±10%, 50mA (short-circuit proof)

Outputs (extra code)

3 relays	changeover (SPDT) (3A, 230V)
----------	------------------------------

Interfaces

Setup interface (standard)	to read and write measurement, instrument, and configuration data (Modbus protocol)
RS232 / RS485 (extra code)	to read and write measurement, instrument, and configuration data (Modbus protocol)
Ethernet (extra code)	to read and write measurement, instrument and configuration data (Modbus-TCP protocol)

Screen

Resolution	320 x 240 pixels
Size	5"
Number of colors	27 colors
Screen refresh rate	≥150Hz
Contrast setting	adjustable on instrument
Screen saver (switch-off)	through waiting time or control signal

Electrical data

Supply (switch-mode PSU)	110 – 240 V AC +10/-15%, 48 – 63Hz or 20 – 53V AC/DC, 48 – 63Hz
Test voltages (type test)	to EN 61 010, Part 1, March 1994 overvoltage category II, pollution degree 2 for supply voltage: AC 2.3kV/50Hz, 1 min, for supply voltage: AC/DC 510V/50Hz, 1 min, for supply voltage: AC 2.3kV/50Hz, 1 min, for supply voltage: AC/DC 510V/50Hz, 1 min
- electrical supply to measuring circuit	350V/50Hz, 1 min
- electrical supply to housing (protective earth)	up to 30V AC and 50V DC
- measuring circuits to other measuring circuits and housing	
- electrical isolation between the analog inputs	
Supply voltage error	< 0.1 % of range span
Power consumption	approx. 25VA
Data backup	see page 6
Electrical connection	At the back, via pluggable screw terminals, conductor cross-section ≤ 2.5mm ² or 2 x 1.5mm ² with core end ferrules.
Electromagnetic compatibility (EMC)	EN 61 326-1 Class A - only for industrial use - to industrial requirements
- interference emission	
- interference immunity	
Safety regulations	to EN 61 010
Enclosure protection	to EN 60 529 category 2, front IP54, back IP20
Ambient temperature range	0 to +50°C
Ambient temperature error	0.03%/°C
Storage temperature range	-20 to +60°C

Housing

Housing type	housing for flush panel mounting to IEC 61 554, galvanized steel sheet
- housing door	zinc die-casting
Bezel size	144 mm x 144 mm
Depth behind panel	214 mm, including connectors
Panel cut-out	138 ^{+1.0} mm x 138 ^{+1.0} mm
Panel thickness	2 – 40 mm
Housing mounting	in panel to DIN 43 834
Climatic conditions	≤ 75% relative humidity, no condensation
Operating position	unrestricted, but taking into account the viewing angle of the screen, horizontally ±50°, vertically ±30°
Enclosure protection	to EN 60 529 Category 2, IP54 front (IP65 with extra code 266), IP20 back
Weight	approx. 3.5kg

Approvals/marks of conformity

Mark of conformity	Testing laboratory	Certificates / certification numbers	Test basis	valid for
c UL us	Underwriters Laboratories	E 201387	UL 61010-1 CAN/CSA-C22.2 No. 61010-1	the flush-mounted instrument; not in conjunction with extra code 350

Operation and configuration

On the recorder

Configuration is menu-led, using 8 keys. Three of these have fixed functions assigned (Enter, Menu, Exit), and five alter their function and visual representation according to the menu. The currently active functions are shown on the bottom edge of the screen, so that key functions are always unambiguous during use.

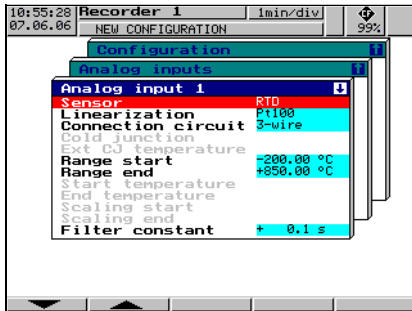

The configuration on the recorder is protected from unauthorized access by a code number.

Via setup program for PC (accessory)

Instrument configuration via the setup program for the PC is more convenient than using the keys on the instrument itself.

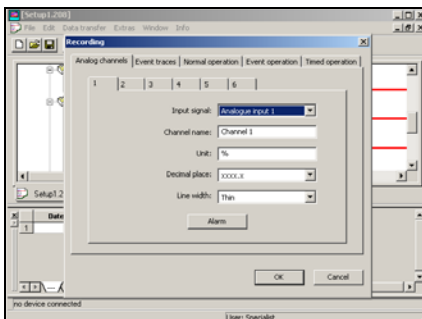

The configuration data can be created on a data medium (CompactFlash card) and read into the recorder, or transferred to the instrument via one of the interfaces. The PC can be used to output the settings to a printer.

Operating language

The operating language for the instrument can be configured in various languages. English, German, French, Dutch, Spanish, Italian, Hungarian, Czech, Swedish, Polish, Danish, Finnish, Portuguese and Russian have been implemented.

Others on request.

Evaluation program

The PC evaluation program (PCA3000) is a program that runs under Windows NT/2000/XP/Vista, and is used to manage, archive, visualize and evaluate the recorder data that have been stored on a CompactFlash card.

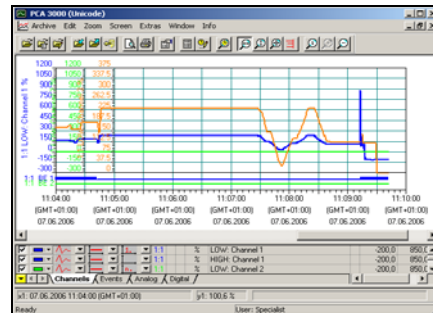

- The data from the LOGOSCREEN 500 cf are read in by the evaluation program and saved in an archive file. The lifecycle data management ensures that, if needed, all the data throughout the lifetime of a system can be saved in an archive file. Changes to the configuration are shown separately, together with the corresponding measurement data.
- The user can gain access at any time to certain data sets (configuration), which can be distinguished by supplementary information. In addition, it is possible to restrict the time periods to be evaluated.
- Any analog channels or event traces of a paperless recorder can subsequently be combined into PCA groups in PCA3000.
- Since each group is displayed in a separate window, several groups can be shown simultaneously on the screen and compared.
- Operation by mouse or keys.
- The export filter makes it possible to export the stored data for processing in another program (e.g. Excel).
- The PCA3000 evaluation program supports network capability, i. e. several users can obtain data from the same database in the network, independently of one another.

PCA communication software (PCC)

- The data can be read out from the paperless recorder via the serial interface (RS232/RS485) on the back, via the Ethernet interface, or via the setup interface on the front. The data can be read out manually or automatically (e.g. daily at 23.00 hrs).
- Data can also be retrieved via remote control, through a modem.

Interface

The current process data, configuration data and special instrument data can be read out via the RS232/RS485 interface (extra code), via the Ethernet interface, or through the setup interface that is fitted as standard. The archive data (FLASH memory) can also be read out, in conjunction with the PCC software.

Serial interfaces

When using the RS232 interface, a maximum cable length of 15m is permitted. A cable length of 1.2km is allowed for the RS485 interface.

Connection is by a 9-pole SUB-D connector (for RS232/RS485) on the back of the instrument, or on the front (via the setup interface). Modbus and Jbus protocols are available, and the transmission mode used is RTU (Remote Terminal Unit).

The changeover between the RS232 and the RS485 interface is made through the program (configuration).

Ethernet interface

Connection is by a RJ45 socket on the back of the instrument. Modbus/TCP is used as a protocol. The maximum transmission rate is 10Mbit/sec.

Extra codes

Counters/integrators/operating time counters

6 additional internal channels are available for use as counters, integrators or operating time counters. These counters are controlled through the binary inputs, the alarms, or via the logic channels. The numerical indication is shown in a separate window, with a maximum of 9 figures. The acquisition period can be selected as: periodic, daily, weekly, monthly, yearly as well as externally, total (overall count) or daily from ... to.

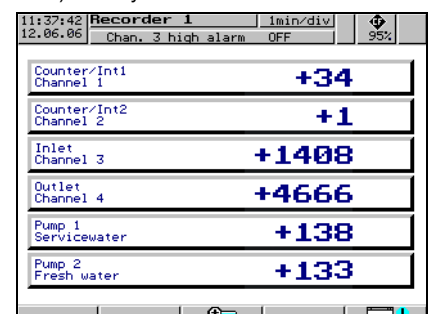

Math/logic module

The module for math and logic (only configurable via the setup software) enables, for instance, the combination of analog channels with one another, with counters and/or with the binary inputs. The operators available for formulae are: +, -, *, /, (,), SQRT(), MIN(), MAX(), SIN(), COS(), TAN(), **, EXP(), ABS(), INT(), FRC(), LOG(), LN(), humidity, moving average or !, &, |, ^, as well as (and).

Operating principle

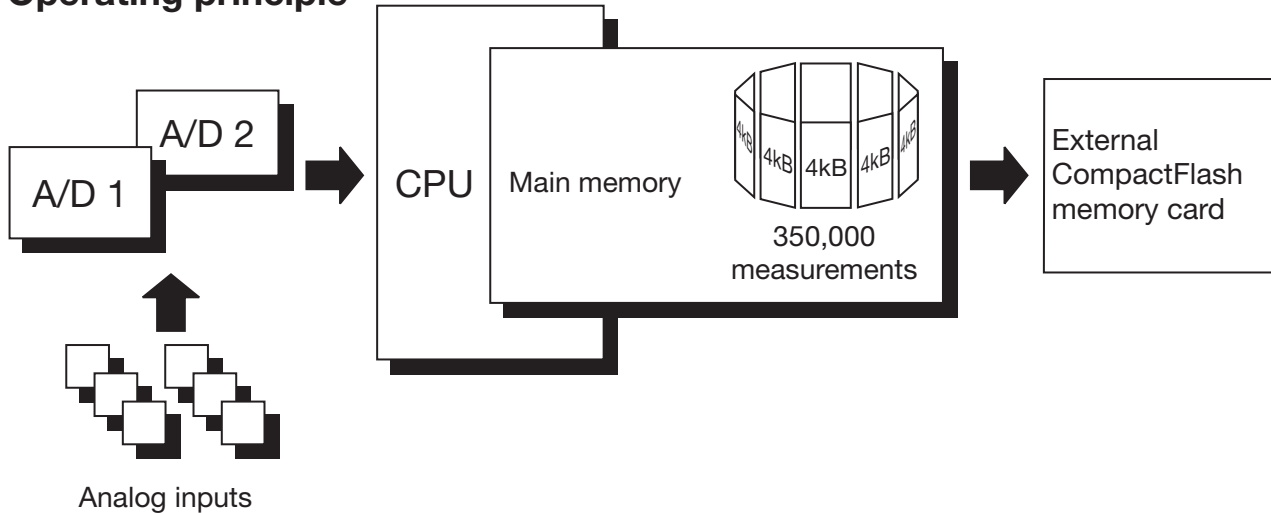

Data processing

The measurements from the analog inputs are acquired continuously in a 250msec sampling cycle. These measurements also serve as the basis for limit monitoring. The measurements are transferred to the main memory of the instrument, according to the configurable storage cycle and stored value (average, momentary value, maximum, minimum, or peak value).

Main memory (FLASH memory)

The data stored in the main memory are regularly copied to the Compact Flash card in 4 kbyte blocks. The main memory is written to as a ring memory, i.e. when it is full, the oldest data will automatically be overwritten by new data. The memory capacity is sufficient for approx. 350,000 measurements.

The instrument monitors the capacity of the main memory and activates the “Memory alarm (internal)” signal if the level falls below a configurable residual capacity.

CompactFlash card

For saving the data, CompactFlash cards (industrial grade) can be used with the following storage capacities: ≤ 2GB. The instrument monitors the capacity of the CompactFlash card, and activates the “Memory alarm (CF card)” signal if the level falls below a configurable residual capacity. This signals can be used, for instance, to operate a relay (warning signal “Swap CF card”).

Data security

The data are stored in coded form in a proprietary format. If the CompactFlash card is removed from the instrument, no data will be lost immediately, as these data are still stored in the FLASH memory. A loss of data will only occur if, after the CompactFlash card has been removed, the FLASH memory is completely rewritten as well.

Response to disconnection of the instrument from the electrical supply

- Configuration and measurement data will be retained, even after the paperless recorder has been disconnected from the electrical supply.
- When the lithium battery, supplied ex-factory, is exhausted (≥ 10years) or the storage capacitor (available on request) is discharged (typically 2 weeks), all measurements that have not yet been saved on a CompactFlash card, as well as the time, will be lost.

Recording duration

Depending on the configuration of the instrument, the duration of the recording can vary over a considerable range (from a few days up to several months).

Limit monitoring/ operating mode changeover

An over/underlimit condition will trigger an alarm. The alarm can be output through a relay or used as a control signal for changing over the operating mode from normal/timed operation to event operation. The storage cycle and stored value can be configured separately for all three operating modes. With the help of the alarm delay function, brief occurrences of over/underlimit conditions can be filtered out, with the result that no alarm is generated.

Normal operation

If the instrument is **not** in event operation and **not** in timed operation, then normal operation is active by default.

Timed operation

Timed operation is active on a daily basis, within a programmable time period.

Event operation

Event operation is activated/terminated by a control signal (binary input, combination alarm). As long as this control signal is active, the instrument is in event operation.

The operating modes have different priorities

Operating mode	Priority
Event operation	1 (higher)
Timed operation	2
Normal operation	3 (lower)

Presentation modes on the instrument

Main menu

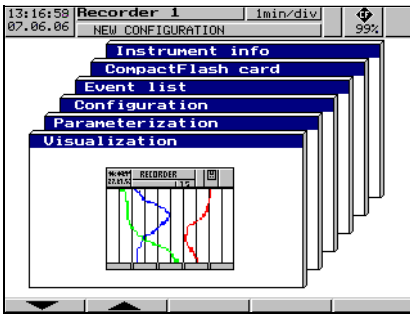

- Branching into the menus (levels)
 - visualization
 - parameterization
 - configuration
 - event list
 - CF card manager
 - device info

Visualization



- Display mode "Measurements" (numerical display)

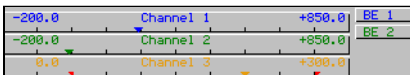

- Display mode "Scaling" including limit markers

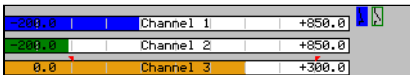

- Display mode "Bar graph" including limit markers

Configuration



- Configuration from instrument keys
- Password-protected
- Configuration can be transferred to CF card
- Configuration data can be read/alterted through the setup program

Visualization

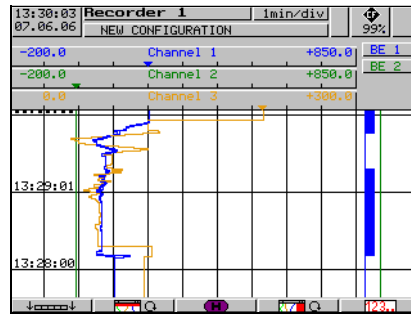

- Analog channels and event traces
- In addition to the curves, measurements can be made visible in numerical form, with scaling or as a bar graphs.
- Softkeys can be made visible or hidden.

Visualization

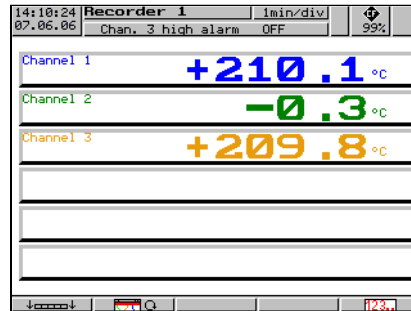

- The graphical presentation can be switched off in favor of a larger numerical display.

Visualization

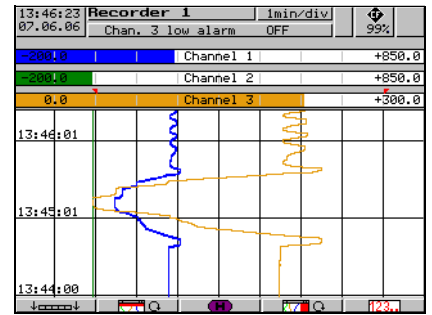

- Graphical presentation of the analog channels (without event traces)
- Display of scaling and limit markers for the channels

History presentation

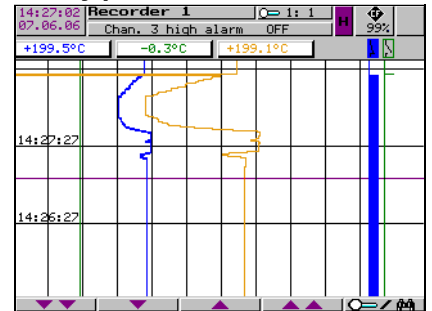

- All measurement data stored in the main memory are shown as curves at different zoom levels.
- Numerical display of the measurements for the analog channels at the cursor position.
- Shifting of the visible section within the stored measurement data.
- When recorded as an envelope: the maximum or minimum value display can be changed within the channel line.

Parameterization



- General settings without password
- Selection of the presentation mode, such as: analog data and/or event traces with/without channel line

Event list

Event list					
07.06.06	14:37:38	Chan. 3 high alarm	OFF		
07.06.06	14:37:38	Chan. 3 low alarm	OFF		
07.06.06	14:37:37	Chan. 3 high alarm	ON		
07.06.06	14:37:37	Chan. 3 low alarm	ON		
07.06.06	14:37:31	POWER ON			
07.06.06	14:37:25	POWER OFF			
07.06.06	14:28:57	Chan. 3 high alarm	OFF		
07.06.06	14:28:57	Chan. 3 low alarm	OFF		
07.06.06	14:28:56	Chan. 3 high alarm	ON		
07.06.06	14:28:56	Chan. 3 low alarm	ON		
07.06.06	14:28:51	POWER ON			
07.06.06	14:28:23	POWER OFF			
07.06.06	14:23:56	Chan. 3 high alarm	OFF		
07.06.06	14:23:56	Chan. 3 low alarm	OFF		
07.06.06	14:23:55	Chan. 3 high alarm	ON		
07.06.06	14:23:55	Chan. 3 low alarm	ON		

- Important events in plain text (alarm messages, external texts or system messages)

Connection diagram

Rear view of a 3/6-channel paperless recorder with pluggable screw terminals

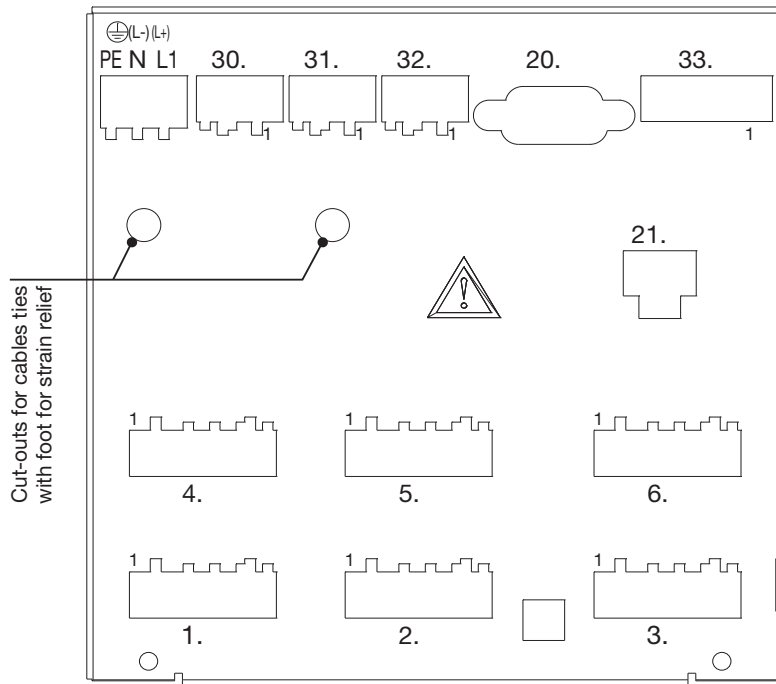

Terminal assignments for 3/6-channel paperless recorder		Diagram
Analog inputs	Connector	
Thermocouple	1 to 6	
RTD in 2-wire circuit	1 to 6	
RTD in 3-wire circuit	1 to 6	
RTD in 4-wire circuit	1 to 6	
Voltage input ≤ 210mV	1 to 6	
Voltage input > 210mV	1 to 6	
Current input	1 to 6	

Supply		
Supply	PE N (L-) L1 (L+)	
Relay outputs (extra code)		
Relays K1, K2, K3 changeover (SPDT)	30, 31, 32	
Setup interface (included in delivery)		
The setup interface can be found behind a protective flap on the front of the instrument.		
Interfaces (extra code)		
RS232 9-pole SUB-D socket (switchable to RS485)	20	2 RxD Received Data 3 TxD Transmitted Data 5 GND Ground
RS485 9-pole SUB-D socket (switchable to RS232)	20	3 TxD+/RxD+ Transmitted/Received Data + 5 GND Ground 8 TxD-/RxD- Transmitted/Received Data -
Ethernet RJ45 socket	21	1 TX+ Transmitted Data + 2 TX- Transmitted Data - 3 RX+ Received Data + 6 RX- Received Data -
Binary inputs (extra code)		
Supply voltage 24V/50mA Binary inputs voltage-controlled LOW = -3 to +5V DC HIGH = 12 to 30V DC	33 6 +24V auxiliary supply 5 GND 4 binary input 1 3 binary input 2 2 binary input 3 1 binary input 4	 Example: binary input 4, operated from the internal supply voltage

Dimensions

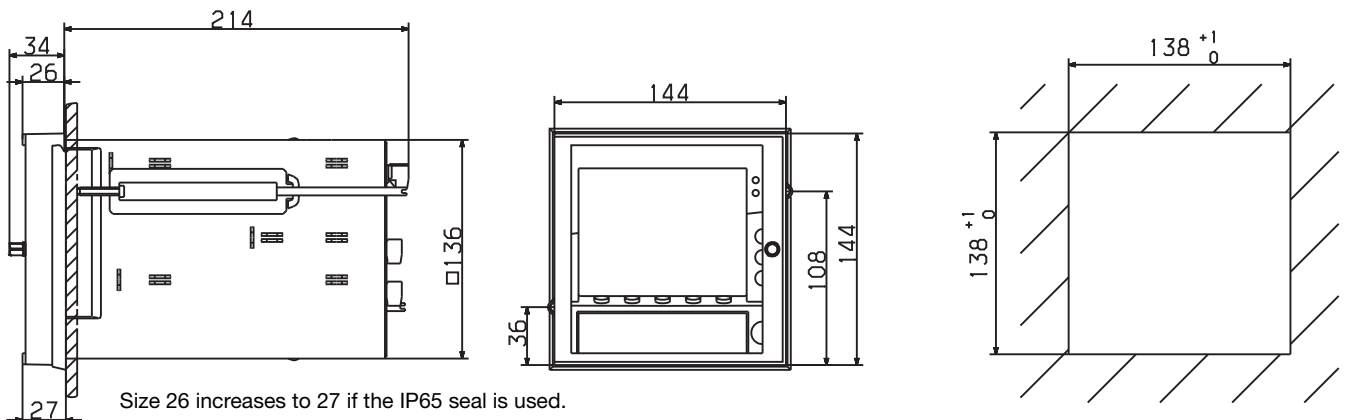

Order details

Entry-level Paperless Recorder with CompactFlash card as storage medium and life-cycle data management

(1) Basic version	
706510/14	Paperless recorder with 3 analog inputs
706510/24	Paperless recorder with 3 analog inputs incl. setup and PC evaluation program (PCA3000)
706510/15	Paperless recorder with 6 analog inputs
706510/25	Paperless recorder with 6 analog inputs incl. setup and PC evaluation program (PCA3000)
(2) Supply voltage	
x x x x 22	20 – 53V AC/DC, 48 – 63Hz
x x x x 23	110 – 240V AC +10/-15%, 48 – 63Hz
(3) Extra codes	
x x x x 008	Ethernet interface
x x x x 020	Lithium battery for memory buffering (ex-factory)
x x x x 021	Storage capacitor (instead of extra code 020)
x x x x 260	Integrators and counters, as well as math and logic module (the math and logic module can only be configured through the setup program).
x x x x 261	4 binary inputs, 3 relay outputs, serial interface RS232/RS485 (Modbus, Jbus)
x x x x 265	Door with lock (IP54)
x x x x 266	IP65 seal, wide mounting brackets
x x x x 350	Universal carrying case TG-35 ¹

Order code	(1)	-	(2)	/	(3)	, ... ²
Order example	706510/14	-	23	/	020	

¹ This extra code is available in combination with supply voltage 110–240V AC, not with low supply voltage. UL approval is not available. The protection type in the carrying case corresponds to IP20, outside IP20D.

² List extra codes in sequence, separated by commas.

Standard accessories

- 1 Operating Manual B 70.6510.0
- 2 mounting brackets
- Cable tie with foot (can be released), for strain relief of the connecting cables to the sensors

Accessories (Data Sheet 70.9700)

	Sales No.
- Setup program, multilingual	70/00467262
- PC evaluation software (PCA3000), multilingual	70/00431882
- PCA communications software (PCC), multilingual	70/00431879
- PC interface with TTL/RS232 converter and adapter (socket)	70/00350260
- PC interface with USB/TTL converter, adapter (socket) and adapter (pins)	70/00456352
- Enabling extra code 260 (configuration of the math and logic module only through the setup program)	70/00393217
- 256 MB CompactFlash memory card	70/00463462

The CF cards specified by JUMO are tested and designed for industrial applications. We do not accept any responsibility for other CF cards.

Universal carrying case TG-35

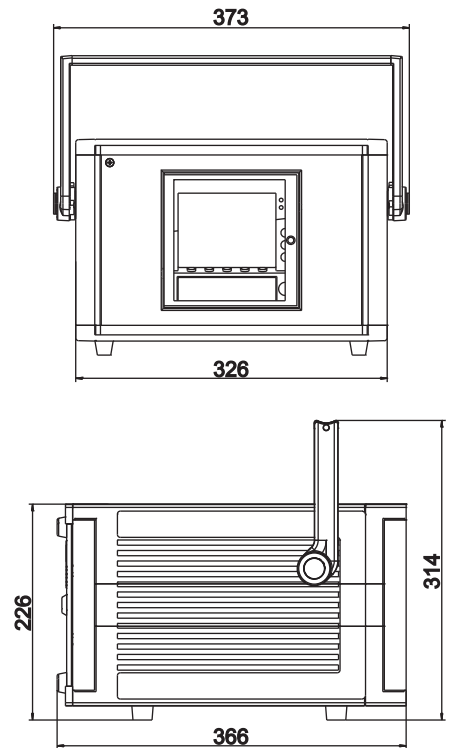

- for the installation of a paperless recorder with bezel size 144mm x 144mm
- 326mm x 226mm x 366mm (W x H x D)
Cut-out: 138mm x 138mm
- The paperless recorder is accessible from the back